

Dolby[®]
Installation Guidelines
for Broadcast and
Professional Products

Issue 2

Dolby Laboratories, Inc.

Corporate Headquarters

Dolby Laboratories, Inc.

100 Potrero Avenue

San Francisco, CA 94103-4813

Telephone 415-558-0200

Fax 415-863-1373

www.dolby.com

European Headquarters

Dolby Laboratories

Wootton Bassett

Wiltshire SN4 8QJ, England

Telephone (44) 1793-842100

Fax (44) 1793-842101

Dolby, Pro Logic, and the double-D symbol are registered trademarks of Dolby Laboratories. Surround EX is a trademark of Dolby Laboratories. All other trademarks remain the property of their respective owners.

© 2002 Dolby Laboratories, Inc. All rights reserved.

S02/13621/14492

Issue 2

Table of Contents

List of Figures	vi
List of Tables	vii
Chapter 1 Overview	
1.1 DP562.....	1-1
1.2 DP563.....	1-1
1.3 DP564.....	1-1
1.4 DP569.....	1-2
1.5 DP570.....	1-2
1.6 DP571.....	1-2
1.7 DP572.....	1-2
1.8 DP579.....	1-2
1.9 DP583.....	1-3
1.10 DM100.....	1-3
1.11 LM100.....	1-3
Chapter 2 Unit Connections and Dimensions	
2.1 DP562.....	2-1
2.1.1 Audio Connections.....	2-1
2.1.2 Serial I/O	2-1
2.1.3 Status Activity and Remote Level Control	2-2
2.2 DP563.....	2-3
2.2.1 Dimensions	2-3
2.2.2 Audio Connections.....	2-4
2.2.3 Serial I/O (Remote).....	2-4
2.2.4 Auxiliary Data	2-4
2.3 DP564.....	2-4
2.3.1 Dimensions	2-5
2.3.2 Audio Connections.....	2-5
2.3.3 Serial I/O (Remote).....	2-5
2.3.4 General Purpose Input/Output (GPI/O).....	2-5
2.3.5 LTC Output	2-6
2.3.6 10/100Base-T	2-6
2.4 DP569.....	2-6
2.4.1 Dimensions	2-6
2.4.2 Audio Connections.....	2-7
2.4.3 Vertical Interval Timecode Input.....	2-7
2.4.4 Linear Timecode Input	2-7
2.4.5 TTL Delay Input.....	2-7

2.4.6	Serial I/O (Remote)	2-7
2.4.7	General Purpose Input/Output (GPI/O)	2-8
2.4.8	Auxiliary Data	2-10
2.5	DP570	2-10
2.5.1	Dimensions	2-11
2.5.2	Audio Connections	2-11
2.5.3	Video Reference	2-12
2.5.4	Serial I/O (Remote)	2-12
2.5.5	General Purpose Input/Output (GPI/O)	2-12
2.5.6	Metadata Inputs	2-13
2.5.7	Metadata Output	2-13
2.5.8	10Base-T	2-13
2.6	DP571	2-13
2.6.1	Dimensions	2-14
2.6.2	Audio Connections	2-14
2.6.3	Video Reference	2-14
2.6.4	LTC Input	2-14
2.6.5	Serial I/O (Remote)	2-14
2.6.6	General Purpose Input/Output (Status Port)	2-14
2.6.7	Auxiliary Data	2-16
2.6.8	Metadata Input	2-16
2.6.9	10Base-T	2-16
2.7	DP572	2-16
2.7.1	Dimensions	2-16
2.7.2	Audio Connections	2-17
2.7.3	Video Reference	2-17
2.7.4	LTC Output	2-17
2.7.5	Serial I/O (Remote)	2-17
2.7.6	General Purpose Input/Output (Status Port)	2-17
2.7.7	Auxiliary Data	2-19
2.7.8	Metadata Output	2-19
2.7.9	10Base-T	2-19
2.8	DP579	2-20
2.8.1	Dimensions	2-20
2.8.2	Connections	2-20
2.9	DP583	2-20
2.9.1	Dimensions	2-20
2.9.2	Audio Connections	2-21
2.9.3	Reference Inputs	2-21
2.9.4	Serial I/O (Remote)	2-21
2.9.5	General Purpose Input/Output (Status Port)	2-21

2.10	DM100	2-22
2.10.1	Dimensions.....	2-22
2.10.2	Audio Connections	2-22
2.10.3	Video Reference.....	2-22
2.11	LM100.....	2-22
2.11.1	Dimensions.....	2-22
2.11.2	Audio Connections.....	2-23
2.11.3	Serial I/O (Remote)	2-23
2.11.4	General Purpose Input/Output (GPI/O)	2-23
2.11.5	Alarm Port.....	2-23

Chapter 3 Installation Issues

3.1	Venting.....	3-1
3.2	Timing and Delays	3-1
3.2.1	Dolby Surround	3-1
3.2.2	Dolby Digital.....	3-2
3.2.3	Dolby E	3-2
3.3	Setup and Calibration.....	3-2

Chapter 4 Hot Standby and Alarms

4.1	DP562.....	4-1
4.2	DP563.....	4-1
4.3	DP564.....	4-1
4.4	DP569.....	4-1
4.5	DP570.....	4-2
4.6	DP571.....	4-2
4.7	DP572.....	4-3
4.8	DP583.....	4-3
4.9	LM100.....	4-3

Chapter 5 Common Applications and Wiring

5.1	DVD Authoring	5-1
5.2	Monitoring Dolby E/Dolby Digital and Dolby Surround Production	5-2
5.2.1	Using a DP570	5-2
5.2.2	Monitoring with a DP569 and DP562/4	5-3
5.2.3	Monitoring Content Ingest Using the LM100.....	5-4
5.2.4	Off-Air Monitoring with the LM100.....	5-5

Chapter 6 Serial Communications

6.1	RS-232 Ports	6-1
6.2	RS-485.....	6-2
6.3	Metadata Connections	6-3
6.4	Serial Control.....	6-4

List of Figures

Figure 2-1 Front and Back Panels of the DP562.....	2-1
Figure 2-2 Test Box Schematic	2-3
Figure 2-3 Front and Back Panels of the DP563.....	2-3
Figure 2-4 Front and Back Panels of the DP564.....	2-4
Figure 2-5 The Cat. No. 549 GPIO Controller.....	2-6
Figure 2-6 Front and Back Panels of the DP569.....	2-6
Figure 2-7 Front and Back Panels of the DP570.....	2-10
Figure 2-8 Front and Back Panels of the DP571.....	2-13
Figure 2-9 Front and Back Panels of the DP572.....	2-16
Figure 2-10 Diagram of Voiceover and Switched Output Operation.....	2-19
Figure 2-11 Front and Back Panels of the DP579.....	2-20
Figure 2-12 Front and Back Panels of the DP583.....	2-20
Figure 2-13 Front and Back Panels of the LM100.....	2-22
Figure 4-1 Hot Standby Operation of the DP569.....	4-2
Figure 5-1 Typical DVD Encoding System	5-1
Figure 5-2 Example Equipment Setup for Postproduction Studio or OB Truck.....	5-2
Figure 5-3 Example Equipment Setup for use with Consoles with Full Monitoring Functions	5-3
Figure 5-4 Dolby Digital/Surround Monitoring	5-4
Figure 5-5 LM100 for Ingest Monitoring	5-4
Figure 5-6 LM100 for Off-Air Analog Monitoring.....	5-5
Figure 6-1 Metadata Multidrop.....	6-4

List of Tables

Table 2-1 Pin Connections for Status/Remote Port	2-2
Table 2-2 Pin Connections for the DP564 GPI/O Connector	2-5
Table 2-3 Pin Connections of GPI/O In Port	2-8
Table 2-4 Pin Connections of GPI/O Out Port	2-9
Table 2-5 Pin Connections for the Cat. No. 548 Analog Option Card Multichannel Output.....	2-11
Table 2-6 Pin Connections for the Cat. No. 548 Analog Option Card Stereo/Mono Output	2-12
Table 2-7 Pin Connections for the DP570 GPI/O Connector	2-13
Table 2-8 Pin Connections of GPI/O Port.....	2-15
Table 2-9 Status Port Preset Selection	2-15
Table 2-10 Preset Mode Tally Indication on Status Port.....	2-16
Table 2-11 Pin Connections for the Status Port	2-18
Table 2-12 Status Port Output-Routing Mode Selection	2-18
Table 2-13 Status port connections	2-21
Table 2-14 Pin Connections of GPI/O Port.....	2-23
Table 2-15 Pin Connections of Alarm Port	2-24
Table 3-1 Dolby Digital Coding and Decoding Delays.....	3-2
Table 6-1 Pin Connections for 9-Pin RS-232 Ports (DP562 and DP572).....	6-1
Table 6-3 Pin Connections for 9-Pin RS-232 Ports (DP571).....	6-2
Table 6-4 Pin Connections for 8-Pin RS-232 Ports.....	6-2
Table 6-5 Pin Connections for RS-485 Ports (excluding Metadata Outputs).....	6-3
Table 6-6 Pin Connections for Metadata Output Ports	6-3

Chapter 1

Overview

This document is designed to help users correctly install Dolby pro audio products into broadcast, postproduction, and other environments. Operation of each unit is not covered in this document; for this information, refer to the dedicated user manual supplied with each unit. Additional copies of user manuals can also be obtained from Dolby Laboratories.

Upon purchasing a new Dolby product, please register it at www.dolby.com. Doing so enables us to notify you of product upgrades and, if you wish, send you other information of interest.

The units detailed in this document are the DP562, DP563, DP564, DP569, DP570, DP571, DP572, DP579, DP583, DM100, and LM100.

1.1 DP562

The DP562 has been superseded by the DP564, but existing units are supported by Dolby Laboratories. It is a multichannel reference decoder incorporating both Dolby® Digital (AC-3) and Dolby Surround Pro Logic® decoding. When producing material in Dolby Surround, the unit allows the effects of the encode/decode process to be monitored. When used for monitoring Dolby Digital encoding, it allows the effects of metadata to be auditioned, and the various downmixes to be heard.

1.2 DP563

The DP563 is a digital implementation of the Dolby Surround matrix encoder used in the analog SEU4 Dolby Surround Encoder. It has six digital inputs so that 5.1 material can be automatically downmixed to four channels before it is encoded. This unit is usually used in conjunction with a DP562 or DP570.

1.3 DP564

The DP564 Multichannel Audio Decoder supercedes the DP562. It is a multichannel reference decoder incorporating decoding and monitoring of Dolby Digital, Dolby Surround Pro Logic and Pro Logic II, PCM, Dolby Digital, and Dolby Digital Surround EX™. When producing material in Dolby Surround Pro Logic or Pro Logic II, the unit allows the effects of the encode/decode process to be monitored.

When used for monitoring Dolby Digital or Surround EX encoding, it allows the effects of metadata to be auditioned, and the various downmixes to be heard.

1.4 DP569

The DP569 Dolby Digital Encoder takes up to six input channels (for 5.1-channel operation) and outputs an encoded Dolby Digital bitstream. The DP569 can use metadata generated by another unit and can be controlled by a PC running Microsoft® Windows® using the supplied DolbyRemote software. A DP564 or DP562 is used to monitor the encoded Dolby Digital bitstream.

1.5 DP570

The DP570 Multichannel Audio Tool allows users to generate metadata for input into either a Dolby E or Dolby Digital encoder, and to monitor the effects of metadata on an audio source in real time. It also includes features such as multiple speaker selection, audio channel routing (which eliminates the need for an external router), and separate inputs for Dolby Surround Pro Logic decoding and 5.1-channel monitor configuration.

1.6 DP571

The DP571 Dolby E Encoder encodes up to eight PCM audio channels plus Dolby Digital metadata into a single AES3 channel pair. Its one-frame PCM audio delay keeps linear PCM audio in sync with Dolby E encoded audio.

1.7 DP572

The DP572 Dolby E Decoder decodes up to eight channels of high-quality PCM audio plus Dolby Digital metadata from a single AES3 pair encoded in Dolby E, or from two audio tracks on a digital videotape, digital audio tape, or video server.

1.8 DP579

The DP579 is a tri-level sync interface for Dolby E. It allows Dolby E multichannel audio and metadata to be stored on 24-frame acquisition and storage systems using existing DP571 and DP572 Dolby E encoder and decoder products. It converts tri-level sync into a reference signal known as *Dolby Black*. It also passes through standard PAL and NTSC reference signals.

1.9 DP583

The DP583 is a frame synchronizer that accepts Dolby Digital, Dolby E, and PCM audio inputs and provides an output synchronized to match the local plant reference. It can operate with both a tracking and a fixed delay of up to 310 ms for each audio format. The output clock can be derived either from a video black reference or an AES reference.

1.10 DM100

The DM100 Bitstream Analyzer is a very useful tool for installation engineers. It is a handheld, portable diagnostic tool that can monitor Dolby Digital, Dolby E, and PCM bitstreams. It can also generate test streams in any of these formats.

1.11 LM100

The LM100 is a Broadcast Loudness meter, designed to measure subjective loudness of broadcast programming. It accepts Dolby E, Dolby Digital, and PCM audio as digital inputs; two-channel analog (baseband) inputs; and, optionally, “in the clear” analog CATV and off-air NTSC RF signals.

Chapter 2

Unit Connections and Dimensions

2.1 DP562

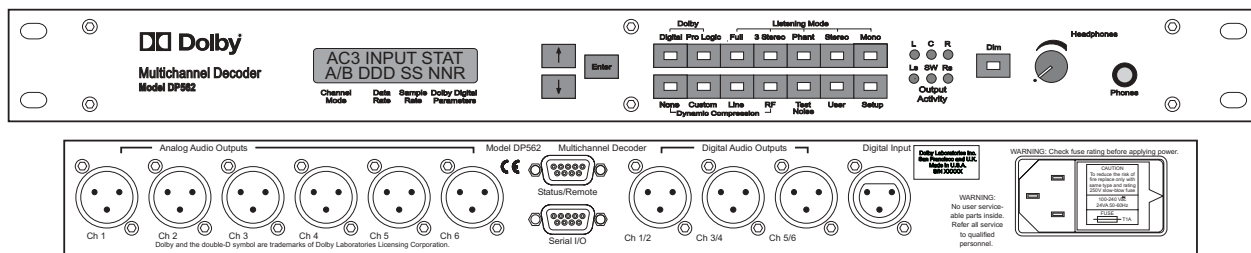

Figure 2-1 Front and Back Panels of the DP562

Dimensions

The DP562 is a 1-U rackmount and measures 45 × 483 × 305 mm (1.75 × 19 × 12 inches). Its net weight is 4.5 kg (9.9 lb).

2.1.1 Audio Connections

The digital audio input is a 3-pin female XLR connector. The input accepts either PCM in AES/EBU format or Dolby® Digital (AC-3) in IEC 1937 format (formerly IEC 958 Annex B) as specified in *ATSC A/52 Annex B*.

The digital audio outputs are 3-pin male XLR connectors. The outputs are PCM in AES/EBU format (5 V_{p-p}, 110Ω).

The analog audio outputs are balanced and use 3-pin male XLR connectors (0 dBFS = +24 dBu). The output impedance is 25Ω.

The headphone output is a quarter-inch standard audio headphone jack with +11.5 dBu maximum output into 600Ω nominal.

2.1.2 Serial I/O

The DP562 has a rear-panel RS-232 port. This port is used for software upgrades and can also be used to control most of the functions of the DP562. The unit must be in Remote Control mode before it can accept commands through the Serial I/O port.

Remote Control mode is enabled in the User menu, which is entered by holding down the User button for three seconds. The LED on the User button illuminates when the user option is selected. This option is available only in version 2.5 or later of the unit software. See Section 6.4 for further information.

The DP562 communicates at 9.6 kbps and has a fixed unit address of 8282.

2.1.3 Status Activity and Remote Level Control

The Status/Remote connector on the rear panel allows remote monitoring of the status output activity and remote control of the analog output level. When the remote level control is enabled, the internal master level control is disabled.

Table 2-1 Pin Connections for Status/Remote Port

Pin	Connection	Comments
1	Fault	Processor/memory fault
2	AC-3/PCM	1 = AC-3 bitstream; 0 = non-AC-3
3	AC-3 CRC Error	AC-3 CRC error encountered during decode
4	AC-3 CRC Error (+5 V)	Pin 3 and pin 4 are closed for 100 ms when a CRC error is detected
5	Ground (and pot "low")	
6	Pot wiper	Controls remote level
7	Pot "hi"	
8	Remote LED	1 = Remote Fader selected
9	Remote Switch	Select Remote Fader

Table 2-1 contains details of the pin connections for the Status/Remote port. The test box shown in Figure 2-2 can be used as an example for monitoring Status/Remote port activity and controlling the analog output level remotely. A 10 k Ω potentiometer is often used for the remote level control.

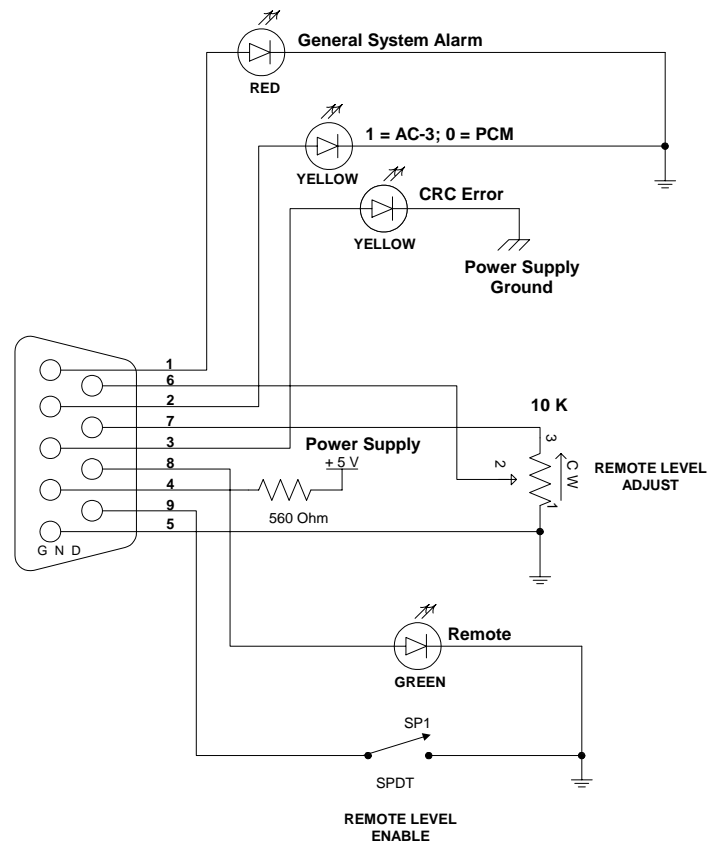

Figure 2-2 Test Box Schematic

2.2 DP563

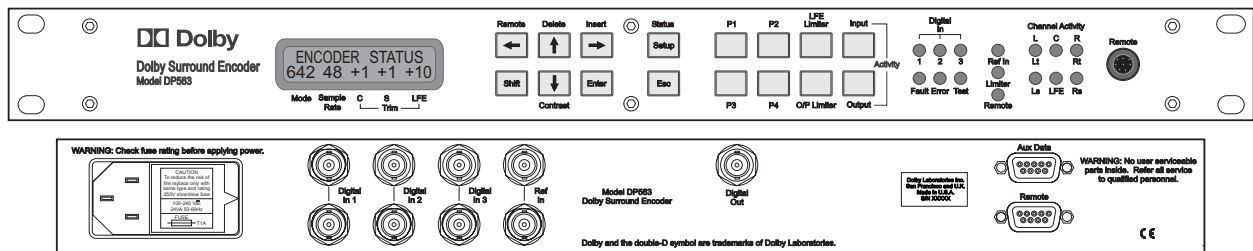

Figure 2-3 Front and Back Panels of the DP563

2.2.1 Dimensions

The DP563 is a 1-U rackmount and measures 44 × 483 × 324 mm (1.75 × 19 × 12.75 inches). Its net weight is 4.6 kg (10.1 lb).

2.2.2 Audio Connections

The digital audio inputs and reference input are provided on female BNC connectors. Input signals should be compliant with AES3-id-1995 (unbalanced, 75Ω, 1 Vp-p standard output). AES3-id signals are very similar to analog composite video, although dedicated AES3 distribution equipment should be used. If the loop-through BNC connectors are not being used to feed additional equipment, terminate them with a standard 75Ω video terminator.

The digital audio output is provided on a female BNC connector. The output is 75Ω, unbalanced, with signal levels compliant with AES3-id-1995.

2.2.3 Serial I/O (Remote)

The DP563 allows remote control via the front-panel (RS-232) or rear-panel (RS-485) ports. It can communicate at rates of 9.6 kbps, 19.2 kbps, or 38.4 kbps. The unit address can be any discrete tributary address as specified in SMPTE RP 113-1996. See Section 6.4 for further information. The default address is 8280, and the serial I/O connections can also be used for software upgrades.

2.2.4 Auxiliary Data

The Aux Data port is an RS-485 port that may be used for future enhancements. See Section 5.2 for pin assignments.

2.3 DP564

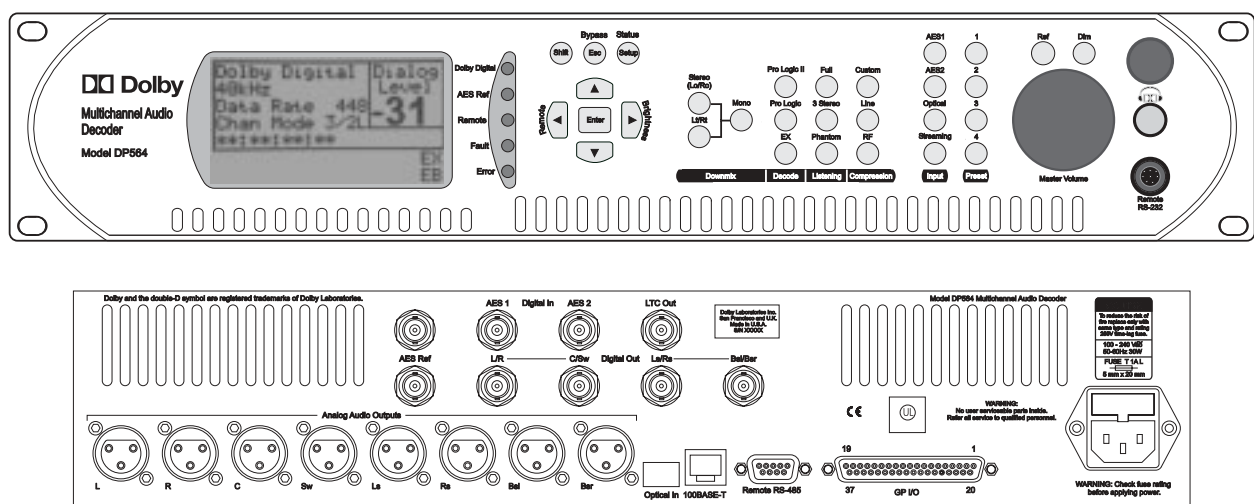

Figure 2-4 Front and Back Panels of the DP564

2.3.1 Dimensions

The DP564 is a 2-U rackmount and measures 88 × 483 × 376 mm (3.5 × 19 × 14.8 inches). Its net weight is 4 kg (8.5 lb).

2.3.2 Audio Connections

The digital audio inputs and outputs and reference inputs are provided on female BNC connectors. Input signals should be compliant with AES3-id-1995 (unbalanced, 75Ω, 1 V_{p-p} standard output). Analog audio output is provided on balanced 3-pin XLR connectors. A headphone output is provided on quarter-inch standard stereo jack. Audio can also be streamed via the Ethernet 10/100Base-T on a RJ-45 connector.

2.3.3 Serial I/O (Remote)

The DP564 has an RS-232, 8-pin female mini-DIN, on the front panel and a RS-485, 9-pin female D-connector (SMPTE 207M) on the rear panel.

2.3.4 General Purpose Input/Output (GPI/O)

The DP564 has a GPI/O port on a 37-pin female D-connector, TTL compatible, which may be configured to be level or edge-sensitive using either polarity.

Table 2-2 Pin Connections for the DP564 GPI/O Connector

Pin	Function	Pin	Function
1	+5 V (150 mA)	7-19	User-defined outputs
2	Fault output	20	Encoder A input
3	Error output	21	Encoder B input
4	User-defined output	22	Encoder present input
5	Bypass	23-36	User-defined inputs
6	Not connected	37	Digital ground

Cat. No. 549

The Cat. No. 549 is a GPI/O controller designed for use with the DP564 and DP570. It features a 37-way connector for direct connection to the GPI/O connector on the main unit. The Cat. No. 549 can control a number of the key functions, including master volume. The functions controlled by the Cat. No. 549 are defined by the GPI/O settings in the main unit.

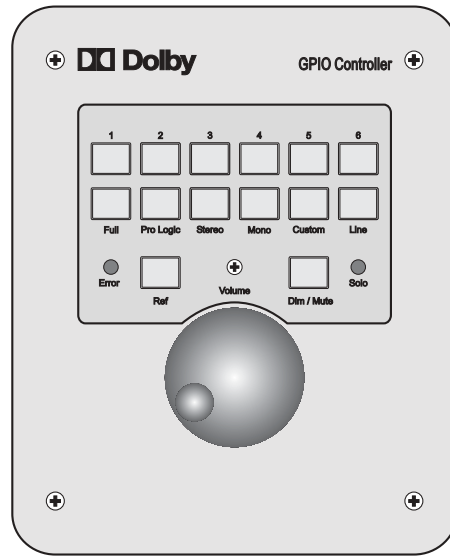

Figure 2-5 The Cat. No. 549 GPIO Controller

2.3.5 LTC Output

The DP564 has linear timecode (LTC) output on a female BNC connector.

2.3.6 10/100Base-T

It also has an Ethernet 10/100Base-T port with auto-detection, on an RJ-45 connector, which can be used for remote control and as an audio streaming input.

2.4 DP569

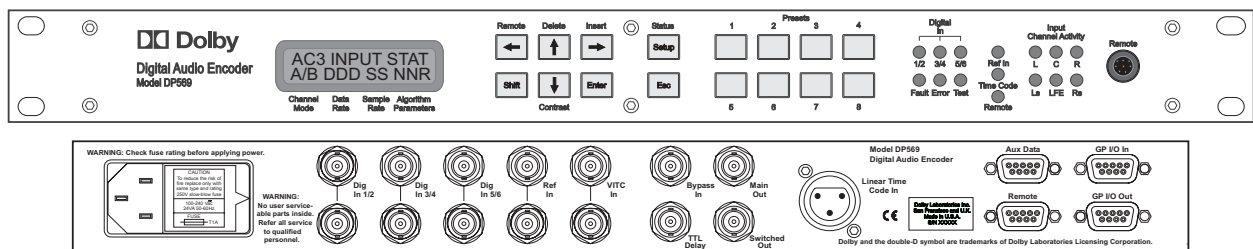

Figure 2-6 Front and Back Panels of the DP569

2.4.1 Dimensions

The DP569 is a 1-U rackmount and measures 44 × 483 × 324 mm (1.75 × 19 × 12.75 inches). Its net weight is 4.7 kg (10.3 lb).

2.4.2 Audio Connections

The digital audio inputs and reference input are provided on female BNC connectors. Input signals should be compliant with AES3-id-1995 (unbalanced, 75 Ω , 1 V_{p-p} standard output). AES3-id signals are very similar to analog composite video, although dedicated AES3 distribution equipment should be used. If the loop-through BNC connectors are not being used to feed additional equipment, terminate them with a standard 75 Ω video terminator.

The main digital output is a female BNC connector. The encoded data is formatted in accordance with the ATSC A/52 Annex B specification, and signal levels are in conformance with AES3-id-1995. The nominal output impedance is 75 Ω .

The bypass input is routed to the switched output when the unit is in bypass mode. The unit enters bypass mode when an internal fault occurs or power to the unit is lost. The operator can also select this mode. The key use for this feature is for “hot standby” operation. See Section 4.3 for further details.

2.4.3 Vertical Interval Timecode Input

If using SMPTE vertical interval timecode (VITC), connect the composite video signal to the VITC In BNC connector using a 75 Ω shielded cable. There is a loop-through connection that requires 75 Ω termination if this facility is not being used.

2.4.4 Linear Timecode Input

If using SMPTE linear timecode (LTC), connect the LTC signal to the LTC input using a male XLR connector.

2.4.5 TTL Delay Input

The TTL delay input can be used to control the encoding delay of the DP569 remotely. This port accepts a TTL level signal with an active high-pulse width that corresponds to the desired delay. It may be driven by a video frame sync or related equipment to automatically match the DP569 encoding delay with an associated video delay.

2.4.6 Serial I/O (Remote)

The DP569 allows remote control of the unit via the front-panel (RS-232) or rear-panel (RS-485) ports. To place the unit into Remote mode, press the Shift button, followed by the left arrow button. Dolby has developed DolbyRemote, a user interface for the Windows[®] operating system. This is supplied with each DP569, and

provides a user-friendly control system for most of the unit's functions. The serial I/O connections can also be used for software upgrades.

The DP569 can communicate at rates of 9.6, 19.2, or 38.4 kbps. The unit address can be any discrete tributary address as specified in SMPTE RP 113-1996. See Section 6.4 for further information.

2.4.7 General Purpose Input/Output (GPI/O)

The GPI/O ports on the DP569 have female 9-pin D-connectors, and operate at 5 V CMOS output levels.

General Purpose Status Input Port (GPI/O In)

Table 2-3 Pin Connections of GPI/O In Port

Pin	Connection	Comments
1	Bypass	Select Bypass Input as source for Switched Output
2	Autodetect	Autodetect and pass-through valid AC-3 signals
3	Pre-encoded	Force Pass-Through mode (no AC-3 encoding)
4	PCM	Force AC-3 encoding (no Pass-through mode)
5	User Preset 1	Select User Preset 1
6	User Preset 2	Select User Preset 2
7	User Preset 3	Select User Preset 3
8	User Preset 4	Select User Preset 4
9	Ground	

Pin 1

Connecting pin 1 to ground (pin 9) places the unit into Bypass mode. This occurs regardless of the setting of the Bypass mode parameter in the I/O control menu. However, enabling Bypass in the menu also places the unit into bypass, regardless of the presence of this connection.

Pins 2–4

To select one of these modes, a high-to-low transition should be placed on a pin. The input format corresponding to the pin is selected, as long as the selection does not conflict with another setting (such as clock source). As only one of these settings can be selected, the input formats become active in the order that they are selected. A low-to-high transition on these pins has no effect.

Pins 5–8

These operate in the same way as pins 2–4. The relevant preset is recalled immediately if a high-to-low transition occurs. If pin 1 is grounded, then bypass operation is active irrespective of the setting of Bypass mode within the preset.

General Purpose Status Output Port (GPIO Out)

Table 2-4 Pin Connections of GPIO Out Port

Pin	Connection	Comments
1	Fault	Power supply or processor/memory fault
2	Lock	Valid input and clock sources present and stable
3	Pass-Through	Valid AC-3 input signal being passed through
4	Encoding	AC-3 encoding of input signal active
5	User Preset 1	User Preset 1 selected
6	User Preset 2	User Preset 2 selected
7	User Preset 3	User Preset 3 selected
8	User Preset 4	User Preset 4 selected
9	Ground	

Pin 1

This output corresponds to the front-panel Fault LED. When a power supply or internal hardware fault is detected, the Fault LED illuminates and the corresponding output signal goes low. When no fault is detected, the LED does not illuminate and the output signal remains high.

Pin 2

This output reports the status of both the selected input and clock sources. A high level on this signal indicates that both sources are “valid” (i.e., locked and stable). A high level does not guarantee a valid output, but only that the input state is valid. A low level implies that a valid output is not being produced.

Pin 3

This output reflects the status of Pass-Through mode. A high level indicates that pass-through is not active. A low level indicates that pass-through is active (i.e., that a valid encoded bitstream is being passed through).

Pin 4

This output reflects the state of the Dolby Digital (AC-3) encoding process. A high-level output indicates that the Dolby Digital encoding process is not active. A low-level output indicates that the Dolby Digital encoding process is active. (This includes test tone modes.)

Note: The combination of the pass-through and encoding outputs indicates the DP569 output status. A low level on either output means that the DP569 is producing a valid encoded output signal.

Pins 5–8

These outputs are directly tied to the respective front-panel preset LEDs. An active preset state causes the corresponding preset LED to illuminate and the corresponding output signal to be low. When the corresponding preset state is not active, the output is high.

2.4.8 Auxiliary Data

The Aux Data port is an RS-485 port. See Section 5.2 for pin assignments. In later versions of the unit software (version 1.17 or later), this port can be used as an input for external metadata. This could be from the metadata output on a DP572 or from another metadata source.

2.5 DP570

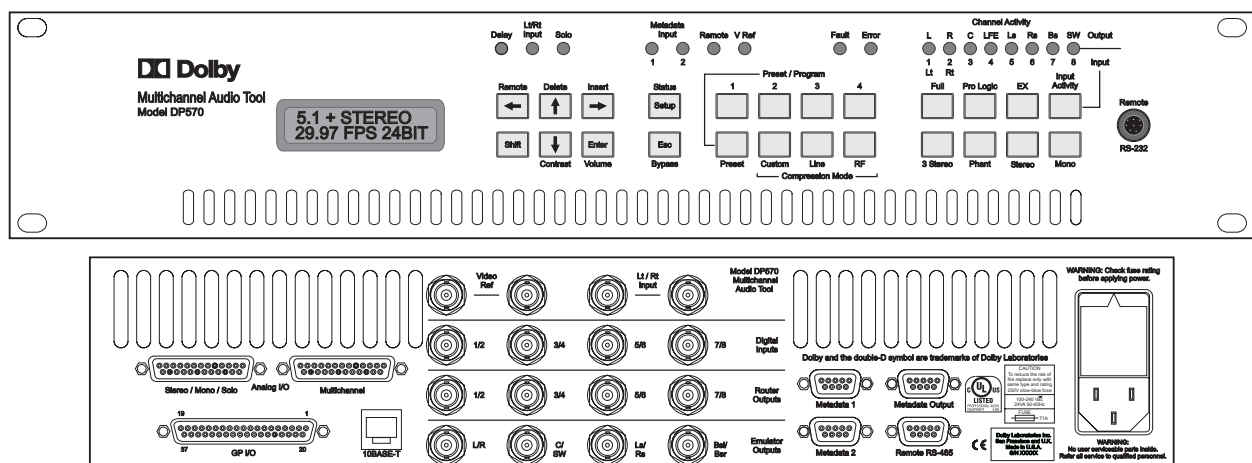

Figure 2-7 Front and Back Panels of the DP570

2.5.1 Dimensions

The DP570 is a 2-U rackmount and measures 88 × 483 × 330 mm (3.5 × 19 × 13 inches). Its net weight is 3.6 kg (7.9 lb).

2.5.2 Audio Connections

The digital audio inputs and Lt/Rt input are provided on female BNC connectors. The Lt/Rt input has a loop-through connection that requires 75Ω termination if this facility is not being used. The inputs should be compliant with AES3-id-1995.

There are two sets of digital audio outputs. One of the sets is from the output of the input router and the other set is from the emulator. The digital audio outputs are provided on a female BNC connector. The output is 75Ω, unbalanced, with signal levels compliant with AES3-id-1995. There are two sets of digital outputs: channel emulator and router outputs.

If the Cat. No. 548 Analog Option Card is fitted, then independent 5.1-channel, two-channel, and mono analog outputs are available. These are provided on two 25-pin D-connectors.

Table 2-5 Pin Connections for the Cat. No. 548 Analog Option Card Multichannel Output

Pin	Connection	Pin	Connection
1	Bsr + Out	14	Bsr – Out
2	Bsr Ground	15	Bsl + Out
3	Bsl – Out	16	Bsl Ground
4	Rs + Out	17	Rs – Out
5	Rs Ground	18	Ls + Out
6	Ls – Out	19	Ls Ground
7	SW + Out	20	SW – Out
8	SW Ground	21	C + Out
9	C – Out	22	C Ground
10	R + Out	23	R – Out
11	R Ground	24	L + Out
12	L – Out	25	L Ground
13	NA		

Table 2-6 Pin Connections for the Cat. No. 548 Analog Option Card Stereo/Mono Output

Pin	Connection	Pin	Connection
1	Digital Ground	14	NA
2	NA	15	NA
3	NA	16	NA
4	NA	17	NA
5	NA	18	Solo In R +
6	Solo In R –	19	SR Ground
7	Solo In L +	20	Solo In L –
8	SL Ground	21	Mono + Out
9	Mono – Out	22	Mono Ground
10	R Stereo + Out	23	R Stereo – Out
11	R Ground	24	L Stereo + Out
12	L Stereo – Out	25	L Ground
13	NA		

2.5.3 Video Reference

A composite video signal should be connected to the video reference BNC connector using a 75Ω shielded cable. There is a loop-through connection that requires 75Ω termination if this facility is not being used.

2.5.4 Serial I/O (Remote)

The DP570 allows remote control via the front-panel (RS-232) or rear-panel (RS-485) ports. See Section 6.4 for further information. The serial I/O connections can also be used for software upgrades.

2.5.5 General Purpose Input/Output (GPI/O)

The DP570 has a 37-pin female D-connector for the GPI/O connections. Most of these connections are user-definable, but there are a few standard connections.

Table 2-7 Pin Connections for the DP570 GPI/O Connector

Pin	Function	Pin	Function
1	+5 V (150 mA)	7–19	User-Defined Outputs
2	Fault Output	20	Encoder A Input
3	Error Output	21	Encoder B Input
4	User-Defined Output	22	Encoder Present Input
5	Solo Tally Output	23–36	User-Defined Inputs
6	Solo Control Input	37	Digital Ground

Cat. No. 549

See Section 2.3.4 for details on the Cat. No. 549 GPIO Controller, which can be used with the DP570.

2.5.6 Metadata Inputs

The metadata input ports are RS-485 ports. These can be used for the input of metadata from a DP572 or other metadata source. See Section 5.2 for pin assignments.

2.5.7 Metadata Output

The metadata output port is an RS-485 port. This can be used for the output of metadata to a DP569, DP571, or other unit with metadata input. See Section 5.2 for pin assignments.

2.5.8 10Base-T

This port will be implemented in future versions.

2.6 DP571

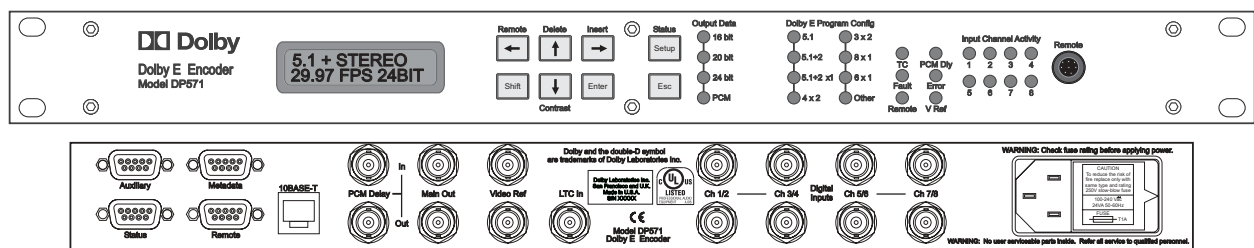

Figure 2-8 Front and Back Panels of the DP571

2.6.1 Dimensions

The DP571 is a 1-U rackmount and measures 44 × 483 × 324 mm (1.75 × 19 × 12.75 inches). Its net weight is approximately 2.7 kg (6 lb).

2.6.2 Audio Connections

The digital audio inputs are provided on female BNC connectors. Input signals should be compliant with AES3-id-1995 (unbalanced, 75Ω, 1 V_{p-p} standard output). AES3-id signals are very similar to analog composite video, although dedicated AES3 distribution equipment should be used. If the loop-through BNC connectors are not being used to feed additional equipment, terminate them with a standard 75Ω video terminator. The PCM delay input is of the same specification, except that no termination is required, as the PCM output is electrically isolated.

The main outputs and the PCM delay output are on female BNC connectors. The output is formatted in accordance with AES3-id-1995. The nominal output impedance for these connectors is 75Ω. The main outputs are electrically isolated and therefore do not require termination.

2.6.3 Video Reference

A composite video signal should be connected to the video reference BNC connector using a 75Ω shielded cable. There is a loop-through connection that requires 75Ω termination if this facility is not being used.

2.6.4 LTC Input

The DP571 accepts a SMPTE LTC signal. After decoding in the LTC receiver, the resulting timecode information is passed to the DSP subsystem.

2.6.5 Serial I/O (Remote)

Future versions of the DP571 will allow remote control via the front-panel (RS-232) or rear-panel (RS-485) ports. See Section 6.4 for further information. The serial I/O connections can also be used for software upgrades.

2.6.6 General Purpose Input/Output (Status Port)

The input and output signals are 0–5 V TTL.

Table 2-8 Pin Connections of GPI/O Port

Pin	Connection	Comments
1	Preset Tally A	Preset tally output
2	Reference Video Valid	1: Valid; 0: Ref video error
3	Dolby E Encoding Valid	1: Valid; 0: Encoding error
4	System Operational	1: Functional 0: Failed
5	Fault	1: Functional 0: Hardware fault
6	Preset Tally B	Preset tally output
7	Preset Ctrl A	Preset control input
8	Preset Ctrl B	Preset control input
9	Ground	—

Pins 1 and 6

Presets 1–3 generate corresponding outputs on the status port that can be used to indicate selection of a preset via the status port, serial remote port (in future versions), or the front panel.

Table 2-9 Status Port Preset Selection

Preset Tally A (Pin 1)	Preset Tally B (Pin 6)	Preset
Low	High	1
High	Low	2
Low	Low	3
High	High	Other or no preset

Pins 2–5

These indicate the current condition of the unit. A “1” corresponds to a high level on the corresponding pin.

Pins 7–8

The two inputs on pins 7 and 8 select among the first three (of eight) presets stored in the DP571. The inputs are normally high (internal pull-up) and trigger a preset recall by sensing a momentary high-to-low transition.

Table 2-10 Preset Mode Tally Indication on Status Port

Pin 7 Transition	Pin 8 Transition	Preset
High-to-Low	None or Low-to-High	1
None or Low-to-High	High-to-Low	2
High-to-Low	High-to-Low	3

2.6.7 Auxiliary Data

The Auxiliary Data port is a 9-pin female RS-232 port that may be used for future enhancements. See Section 5.2 for pin assignments.

2.6.8 Metadata Input

The metadata input port is an RS-485 port. This can be used for the input of metadata from a DP572 or other metadata source. See Section 5.2 for pin assignments.

2.6.9 10Base-T

This port will be implemented in future versions.

2.7 DP572

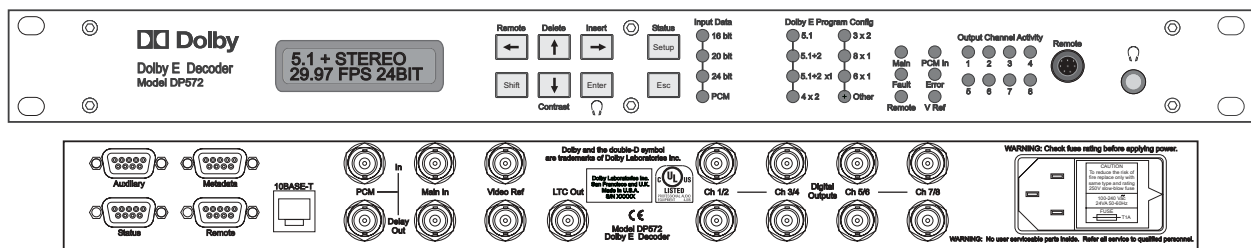

Figure 2-9 Front and Back Panels of the DP572

2.7.1 Dimensions

The DP572 is a 1-U rackmount and measures 44 × 483 × 324 mm (1.75 × 19 × 12.75 inches). Its net weight is approximately 2.7 kg (6.0 lb).

2.7.2 Audio Connections

The main input is provided on a female BNC connector. The inputs should be compliant with AES3-id-1995 (unbalanced, 75 Ω , 1 V_{p-p} standard output). AES3-id signals are very similar to analog composite video, although dedicated AES3 distribution equipment should be used. If the loop-through BNC connectors are not being used to feed additional equipment, terminate them with a standard 75 Ω video terminator. The PCM delay input is of the same specification as the main input, except that no termination is required, as the PCM output is electrically isolated.

The digital outputs and the PCM delay output are on female BNC connectors. The outputs are formatted in accordance with AES3-id-1995. The nominal output impedance for these connectors is 75 Ω . The secondary digital outputs are electrically isolated and therefore no termination is required.

The headphone output is a quarter-inch standard audio headphone jack with +11.5 dBu maximum output into 600 Ω nominal.

2.7.3 Video Reference

A composite video signal should be connected to the video reference BNC connector using a 75 Ω shielded cable. There is a loop-through connection that requires 75 Ω termination if this facility is not being used.

2.7.4 LTC Output

After de-multiplexing timecode information from the Dolby E stream, the DP572 provides a standard SMPTE LTC output.

2.7.5 Serial I/O (Remote)

Future versions of the DP572 will allow remote control via the front-panel (RS-232) or rear-panel (RS-485) ports. See Section 6.4 for further information. The serial I/O connections can also be used for software upgrades.

2.7.6 General Purpose Input/Output (Status Port)

The input and output signals are 0–5 V TTL.

Table 2-11 Pin Connections for the Status Port

Pin	Direction	Connection	Comments
1	Output	Dolby E Detect	1: Dolby E 0: PCM or none
2	Output	Reference Video Valid	1: Valid; 0: Ref video error
3	Output	Dolby E Decoding Valid	1: Valid; 0: Decoding error
4	Output	System Operational	1: Functional 0: Failed
5	Output	Fault	1: Functional 0: Hardware fault
6	Output	Reserved	—
7	Input	PCM Channel Routing	Voiceover and Switched modes
8	Input	PCM Channel Routing	Voiceover and Switched modes
9	N/A	Ground	—

Pins 1–5

These indicate details regarding the current condition of the unit. A “1” corresponds to a “high” level on the corresponding pin.

Pins 7–8

These can be used to select Voiceover and Switched Out modes. The state of the pins is normally high (internal pull-up), and they detect a high-to-low transition. A held contact closure between pins 7 and 9 (ground) or pins 8 and 9 is required to activate a function. A low-to-high transition (i.e., a switch release) restores the Delay Out setting. Table 2-12 shows the function of the two GPI pins on the DP572.

Table 2-12 Status Port Output-Routing Mode Selection

Ctrl in Pin 8	Ctrl in Pin 7	PCM Chan Config Output Routing Mode
High	High	Delay Out
High	Low	Voiceover
Low	High	Switched Out
Low	Low	Reserved

Figure 2-10 details the channel routing of Voiceover and Switched Out modes for a 5.1 input.

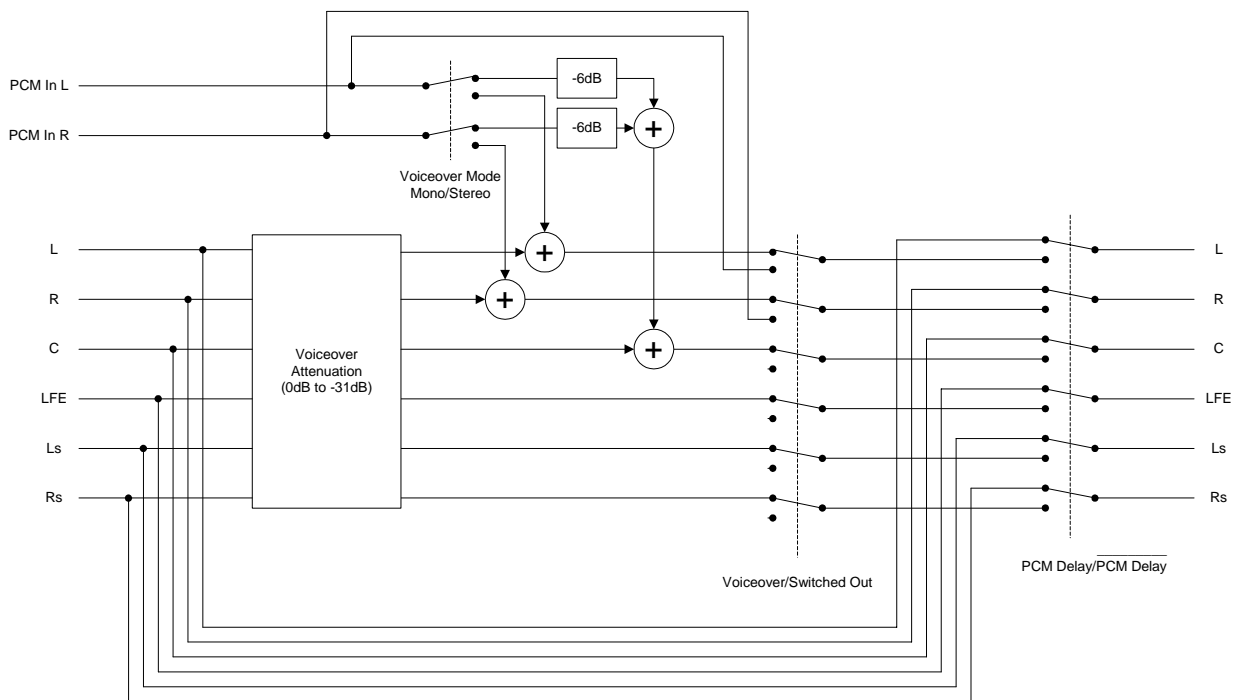

Figure 2-10 Diagram of Voiceover and Switched Output Operation

Use the Voiceover and Switched Output functions when only basic control and editing functions are required. One example may be a local transmission center where the switched output could be used to insert a local commercial delivered as stereo PCM audio. The DP572 can also be used to insert voiceovers. This is advantageous, because recording the voiceover might otherwise require 5.1-channel editing facilities.

2.7.7 Auxiliary Data

The Auxiliary Data port is a 9-pin male RS-232 port that may be used for future enhancements. See Section 5.2 for pin assignments.

2.7.8 Metadata Output

The metadata output port is an RS-485 port. This can be used for the output of metadata to a DP569, DP571, or other unit with metadata input. See Section 5.2 for pin assignments.

2.7.9 10Base-T

This port will be implemented in future versions.

2.8 DP579

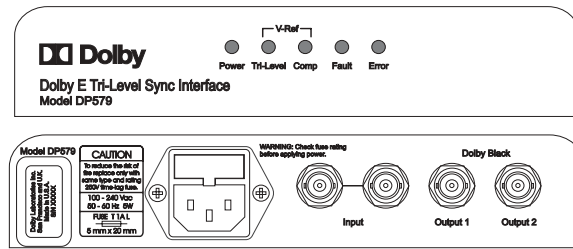

Figure 2-11 Front and Back Panels of the DP579

2.8.1 Dimensions

The DP579 is a half-width 1-U rackmount, measuring 200 × 120 × 40 mm (7.9 × 4.7 × 1.6 inches). Two units can be mounted in one rack space using an optional rack mounting kit. Its net weight is 0.7 kg (1.5 lb).

2.8.2 Connections

The DP579 has a video reference input with loop-through connection and two Dolby Black outputs, all on female BNC connectors.

2.9 DP583

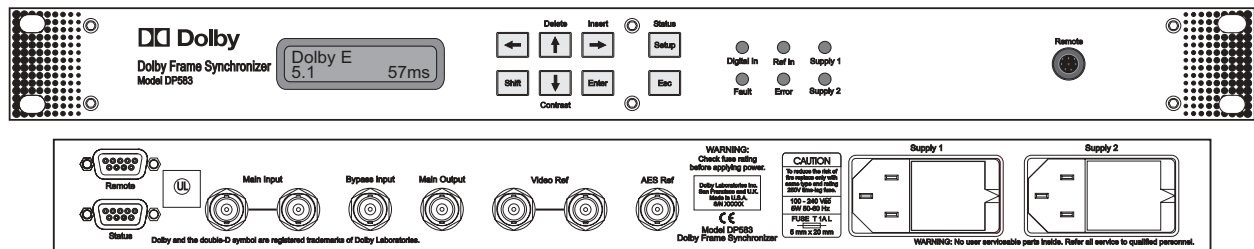

Figure 2-12 Front and Back Panels of the DP583

2.9.1 Dimensions

The DP583 is a 1-U rackmount and measures 44 × 483 × 324 mm (1.75 × 19 × 12.75 inches). Its net weight is 2.9 kg (6.3 lb).

2.9.2 Audio Connections

The digital audio input with loop-through, bypass input, and digital audio outputs on the DP583 are all provided on female BNC connectors. Inputs should be compliant with AES3-id-1995.

2.9.3 Reference Inputs

There is a video reference input on a female BNC connector, with loop-through, that accepts NTSC/PAL program or black as input. There is also an AES reference input on a female BNC connector that accepts SMPTE 276M.

2.9.4 Serial I/O (Remote)

The DP564 has an RS-232, 8-pin female mini-DIN on the front panel and an RS-485, 9-pin female D-connector (SMPTE 207M) on the rear panel.

2.9.5 General Purpose Input/Output (Status Port)

The status port uses a 9-pin female D-connector.

Table 2-13 Status Port connections

Pin	Direction	Connection	Comments
1	Input	Force Bypass Mode	0: Do not force Bypass mode. 1: Force Bypass mode.
2	Output	Reference Valid	1: Reference source is valid. 0: Reference source is invalid.
3	Output	Power Supply Status	0: Power supplies OK. 1: Power supply error.
4	Output	System Operational/Error	0: Error condition detected; output no longer valid. 1: Operational
5	Output	Fault	0: Hardware fault. 1: Functional.
6	Input	Delay Pulse Input	Positive period defines external delay; active high, range 0–80 ms.
7	Output	Delay Pulse Output	Positive period defines amount of delay being applied; active high, range 0–80 ms.
8	Output	Dolby E Framing	0: Video Ref rate matches Dolby E rate. 1: Video Ref rate does not match Dolby E rate.
9	N/A	Signal Ground	

2.10 DM100

2.10.1 Dimensions

The DM100 is a handheld device that measures $100 \times 200 \times 41$ mm ($4 \times 7.9 \times 41$ inches). Its net weight is 0.68 kg (1.5 lb).

2.10.2 Audio Connections

Audio I/O is available on XLR, BNC, or Toslink™ connectors. The female XLR connection has an internal 110Ω termination, and the female BNC input has an internal 75Ω termination. The male XLR output has 110Ω impedance, and the female BNC output has 75Ω impedance.

2.10.3 Video Reference

A composite video signal can be connected to the video reference input via a female phono connector. There is an internal 75Ω termination. A phono-to-BNC adapter is supplied with the DM100.

2.11 LM100

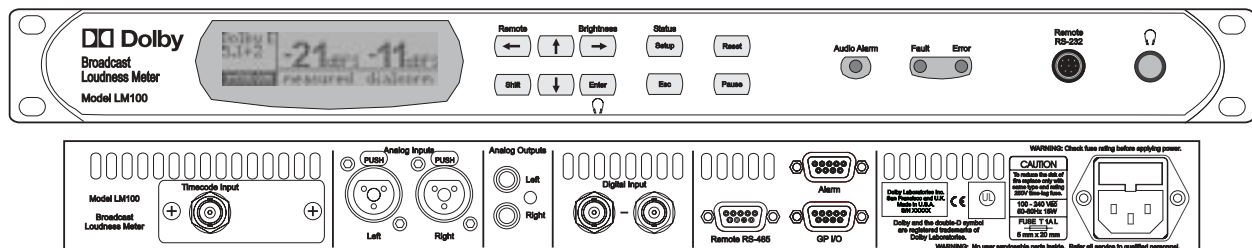

Figure 2-13 Front and Back Panels of the LM100

2.11.1 Dimensions

The LM100 is a 1-U rackmount and measures $44 \times 483 \times 375$ mm ($1.75 \times 19 \times 14.75$ inches). Its net weight is 2.5 kg (5.5 lb).

2.11.2 Audio Connections

The digital audio inputs are BNC female connectors and support PCM, Dolby Digital, and Dolby E. Analog inputs are provided on Neutrik® combination XLR/quarter-inch TRS connectors. F-type female connectors are available as an option and can be used to input CATV or off-air NTSC-M signals. Analog outputs are on stereo unbalanced RCA connectors and a stereo headphone jack.

2.11.3 Serial I/O (Remote)

The LM100 has an RS-232, 8-pin female mini-DIN on the front panel and an RS-485, 9-pin female D-connector (SMPTE 207M) on the rear panel.

2.11.4 General Purpose Input/Output (GPI/O)

The GPI/O port uses a 9-pin female D-connector. The input and output signals are 0–5 V TTL.

Table 2-14 Pin Connections of GPI/O Port

Pin	Connection	Comments
1	Input	Source select
2	Input	Channel up
3	Input	Channel down
4	Input	Pause
5	Input	Reset
6	Output	Alarm
7	Output	Compressed input
8	Output	Measurement running
9	Signal Ground	

2.11.5 Alarm Port

The alarm port uses a 9-pin female D- connector to output alarm indications.

Table 2-15 Pin Connections of Alarm Port

Pin	Connection	Alarm
1	Output	Input clip
2	Output	Over-modulation
3	Output	Above threshold
4	Output	Below threshold
5	Output	AES input loss
6	Output	Dialnorm
7	Output	Error
8	Output	Fault
9	Signal Ground	—

Chapter 3

Installation Issues

3.1 Venting

Dolby professional audio products are designed to operate within a temperature range of 5° to 45° C. They use natural convection cooling and therefore should not be mounted directly above any heat-generating equipment.

DP-series products, with the exception of the DP564, DP570, and DP583, have vent holes in the top and bottom panels along the left or right edge, depending on the unit (left side for the DP562, DP571, and DP572; right for the DP563 and DP569). The vent holes should not be covered, although units can vent through one another if necessary. In this case, be sure that the venting panels are on the same side on each unit. The number of units that can be vented in this way depends on the conditions of the room in which they are installed.

The DP570, DP564, and LM100 feature vent holes in the front and back of the unit, and can be placed directly above or below other rackmounted gear.

3.2 Timing and Delays

Encoding and decoding adds delay to the audio data. In audio-only situations, this may be of little consequence, but where the audio has associated video material, care should be taken to ensure that these delays are accounted for. This can be achieved by adding the equivalent delay to the video stream, by compensating for the delay at the video encoding stage, or by adding an offset between the timecode of the source tapes. The amount of delay varies depending on the technology being used.

3.2.1 Dolby Surround

The delay associated with the Dolby® Surround encode/decode process is effectively zero. The DP563 does allow for the encoding delay to be varied between minimum (<1 ms) and 100 ms. The DP562 has little latency (approximately 3 ms at 48 kHz) when in Disabled or Reference Bitstream Detect modes, although this increases if bass redirection is used. When in Silent Switch mode, the decoding latency is the same as for Dolby Digital. Silent Switch mode includes a crossfade when the input switches between different formats.

3.2.2 Dolby Digital

The amount of delay added by the Dolby Digital encode/decode process varies, depending upon the sample rate being used. Table 3-1 shows the minimum delay values for encoding. The DP569 allows the encoding delay to be increased to any value between the minimum value and 450 ms. In the DP562, the decode latency values are fixed, dependent on the bitstream detect mode. These are also shown in Table 3-1. The decode latency values for the DP564 vary, depending on the settings in the unit. An indication of the delay through the unit is given in the System Status menu of the unit. The encoding delays are correct for version 2.0.3.1 of the DP569 software. It is possible that these may change in later versions.

Table 3-1 Dolby Digital Coding and Decoding Delays

Sample Rate	DP569 Minimum Coding Delay	DP562 Latency in Disabled/Reference Detect	DP562 Latency in Silent Switch Mode
48 kHz	187 ms	32 ms	36.6 ms
44.1 kHz	204 ms	35.7 ms	42.8 ms
32 kHz	280 ms	48.4 ms	58.3 ms

3.2.3 Dolby E

The Dolby E encoding and decoding processes add one frame of delay each to the audio. The frame length is that of the incoming video reference signal. If the DP572 is in Program Play mode, then the decoding delay varies, depending on the rate of the incoming Dolby E bitstream.

The Dolby E units also have a PCM delay output. This can be used to route the PCM input to the PCM output adding the same delay as is being added by the Dolby E encode process. This can be used to keep a pair of unencoded audio channels, such as channels three and four from a VTR, in sync with the encoded audio.

3.3 Setup and Calibration

To allow correct monitoring of the encoded audio, the DP562 includes adjustments for settings such as analog output level trims and surround delays. For details of how these should be set, please refer to the User's Manual.

The DP564 features similar adjustments to the DP562. For details of how these should be set, please refer to the User's Manual.

The DP563 requires calibration with the studio's operating level. For details of how to perform this calibration, please refer to the User's Manual.

The DP570 has different setup options, depending on whether the Cat. No. 548 Analog Option Card is fitted. With the analog board fitted, the setup options are similar to those of the DP562. However, the DP570 allows multiple sets of speakers, for which level trims can be assigned individually. The DP570 also includes Dolby Digital Surround EX™ decoding and can therefore support setups of up to 7.1 speakers. For full details of setting up these speakers, please refer to the User's Manual.

Chapter 4

Hot Standby and Alarms

Many Dolby products allow simple implementation for hot standby applications. Hot standby units and redundancy should be considered at a system level. Systems that utilize hot standby features allow automatic routing of the required signals from a unit that develops a fault to a spare unit in the system. Dolby products can easily be integrated into other redundant systems, such as the “n+1” design that is often used for transmission encoding. In such a system, the only signal that requires routing for the audio is a single Dolby® E stream. Operating status of the units can be assessed by the control, using the GPI/Os.

4.1 DP562

The DP562 features general system alarm and Dolby Digital decoding status signals as outputs on the status/remote port. For further details of the connections of this port, see Section 2.1.3.

4.2 DP563

There are no GPI/O ports on this unit. However, the DP563 only stops encoding when there is no valid audio input on channels 1/2 or if there is a hardware fault.

4.3 DP564

The DP564 has fixed connections on the GP output for fault and error conditions (pins 2 and 3, respectively). However, it is not typical for the DP564 to be installed in a live broadcast path.

4.4 DP569

The DP569 has a bypass input that can be used to make hot standby operation simple. To connect a pair of DP569s for hot standby connection, make the following connections.

The unit automatically enters Bypass mode when an internal fault occurs or when power is lost. Bypass mode can also be selected from the I/O Control menu or via the GPI/O input port.

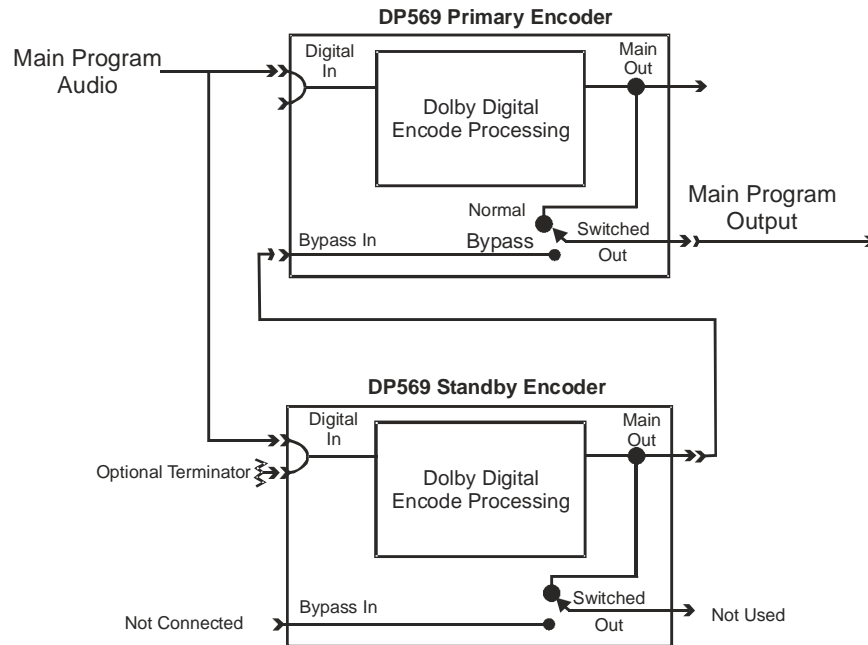

Figure 4-1 Hot Standby Operation of the DP569

For further security, pins 1 and 9 (ground) of the GPI/O ports can be used to control a unit fault alert. If pin 1 goes “low,” this indicates a power supply or hardware fault. These pins can be used on both the encoders so that a faulty standby encoder can be identified before it is required. Pins 3, 4, and 9 can also be used to ascertain whether the unit is producing an encoded output, and trigger a warning on the console or monitor system.

4.5 DP570

The DP570 has fixed connections on the GP output for fault and error conditions (pins 2 and 3, respectively). For critical live applications, the system design should be such that the DP570 is only part of the monitor path or that these pins can be used to trigger routing to bypass the main audio around the DP570.

4.6 DP571

The status port can be used to control a router, console, or other switching device in the event of a unit failure. Pins 4, 5, and 9 (ground) can be used to check whether a unit is operational. If pin 4 or 5 goes “low,” then either the system is not operational,

a hardware fault has occurred, or power has been lost to the unit. By monitoring these pins on both the units, an operator can be alerted to problems with either unit.

4.7 DP572

The DP572 can be used in the same way as the DP571.

4.8 DP583

The DP583 features general fault and error outputs, as well as a number of other outputs on the status port. For further details of the connections of this port, see Section 2.9.5.

4.9 LM100

For details of the LM100 alarm outputs, see Section 2.11.5.

Chapter 5

Common Applications and Wiring

5.1 DVD Authoring

Dolby Laboratories products are often used in the process of authoring DVD discs. The process requires a DP569 and a DP562 or DP564. A DP572 is also required if the audio is supplied in Dolby® E. Using the DolbyRemote software and Dolby Digital recorder package increases ease of use. The Dolby Digital Recorder software utility runs on a Windows® computer with a digital I/O soundcard. See www.dolby.com for compatibility details. The recorder package is used to produce .ac3 format files. Figure 5-1 shows the audio equipment in a typical DVD encoding system.

A Cat. No. 549 can be used to control the DP564.

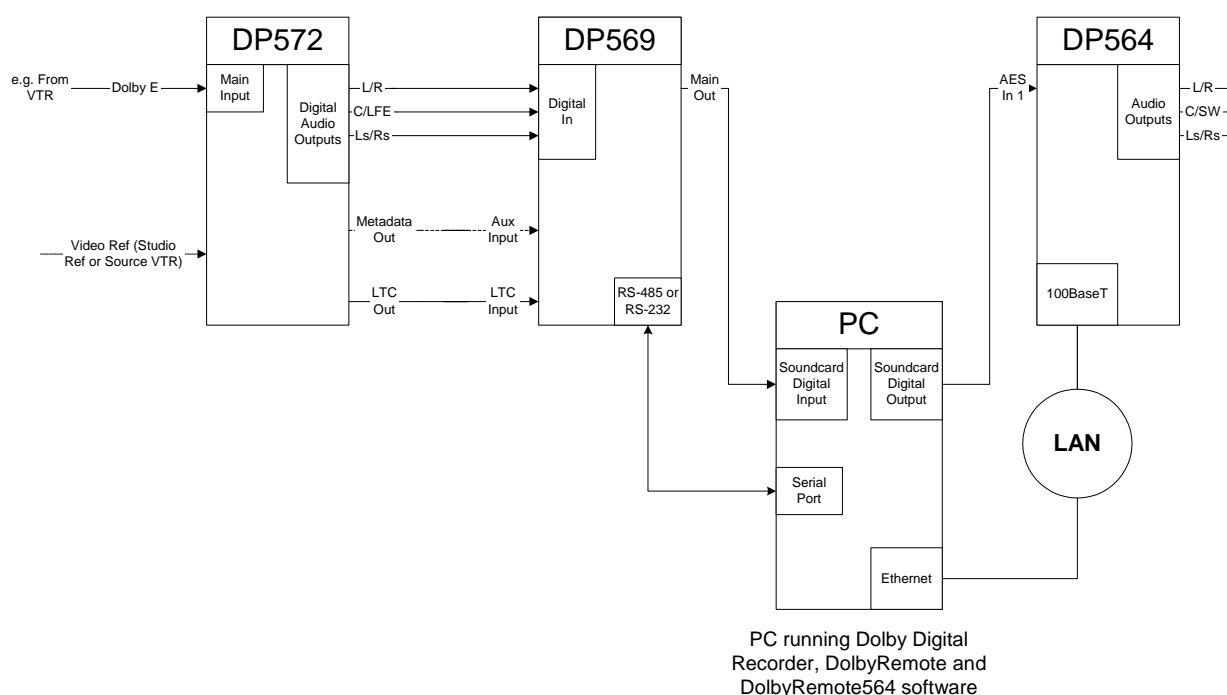

Figure 5-1 Typical DVD Encoding System

Dolby Laboratories can also supply an interface kit for the DP562 and DP569 to aid the installation of this system into studios that use either all balanced or unbalanced digital audio connections. This kit is called the DVD-Audio Cable Kit (Cat. No. 541) and contains four BNC cables along with four impedance transformers. Three of the transformers are female XLR-to-BNC connections, and the fourth one has male XLR-to-BNC connections.

5.2 Monitoring Dolby E/Dolby Digital and Dolby Surround Production

If a 5.1-channel mix is being created simultaneously with a mix encoded in Dolby Surround, the effects of both processes should be monitored.

5.2.1 Using a DP570

A few examples are included in this manual for monitoring 5.1 and Dolby Surround production. There are many variations to these setups that can be used, so a few typical designs are included here.

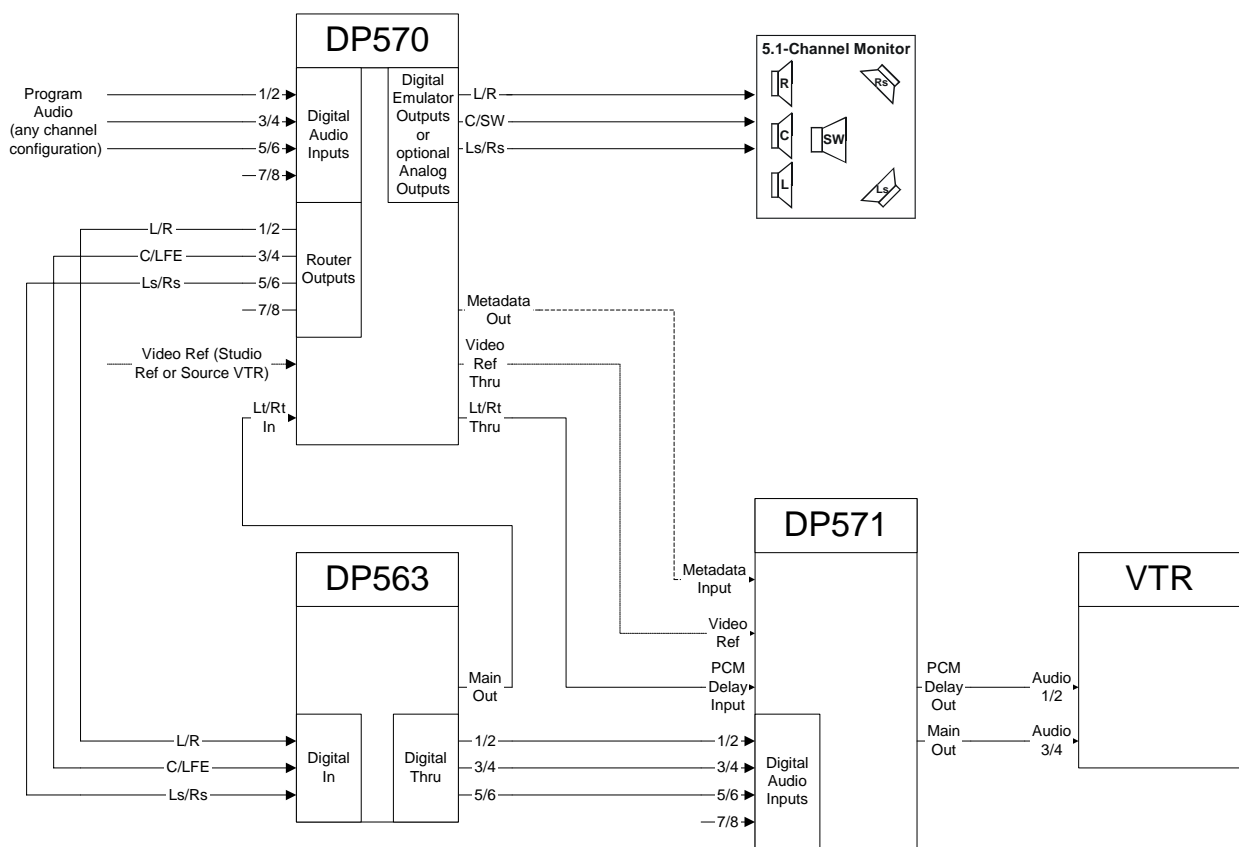

Figure 5-2 Example Equipment Setup for Postproduction Studio or OB Truck.

In Figure 5-2, the program audio is fed to the DP570. The channel order of the audio can be modified using the DP570 router before being fed to the DP563 and DP571. With the Cat. No. 548 analog option card fitted, the DP570 can be used to perform many typical monitoring functions such as level control and channel muting.

In this example, the Lt/Rt audio is connected to the DP570’s Lt/Rt input. This is done when it is not necessary to have metadata associated with the Lt/Rt signal, for example, when the Lt/Rt is being created for use in analog broadcasts.

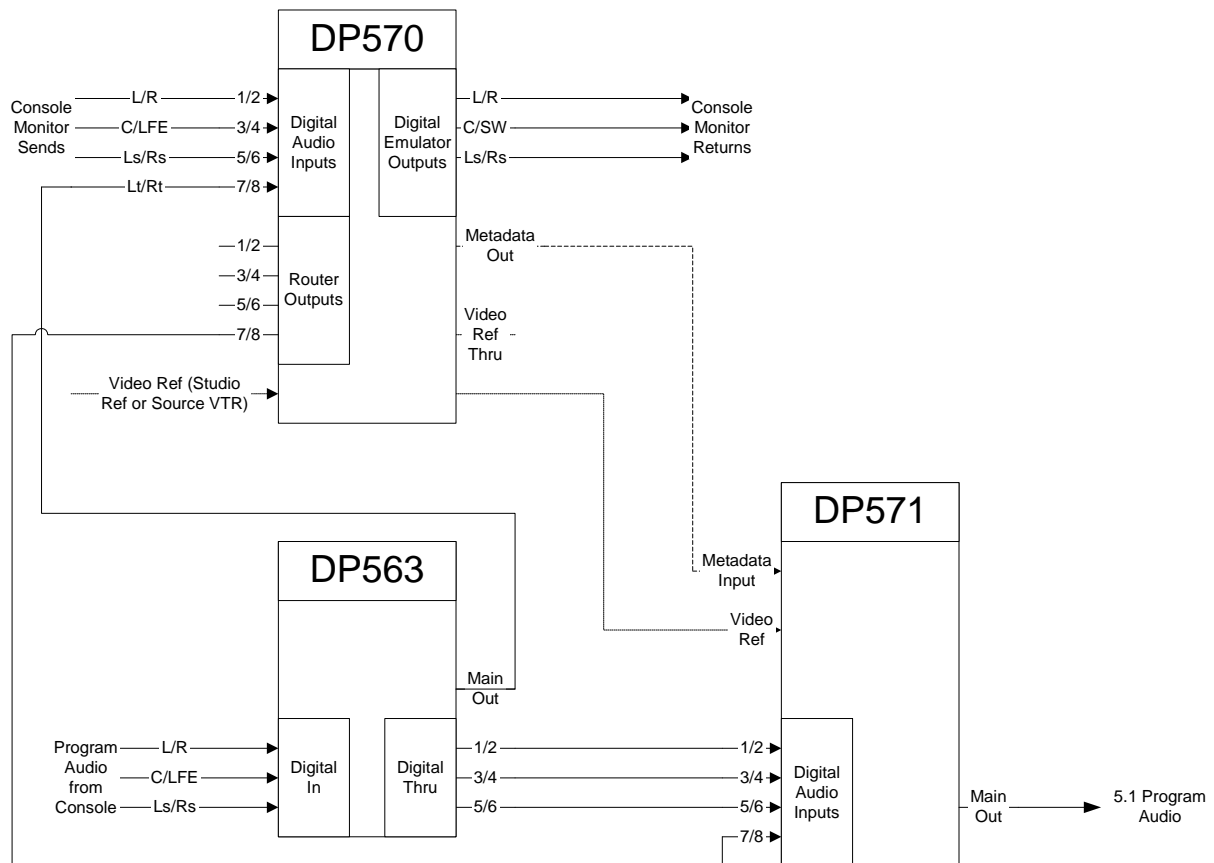

Figure 5-3 Example Equipment Setup for use with Consoles with Full Monitoring Functions

The example in Figure 5-3 shows a setup that uses separate program audio and monitor feeds. In this example, because the DP570 digital emulator outputs are in use, the console being used should feature the required monitoring functions. The Lt/Rt audio is connected to the 7/8 input of the DP570. This enables metadata, which is required for Dolby Digital broadcast of the Lt/Rt or for inclusion on a DVD, to be associated with the Lt/Rt signal.

5.2.2 Monitoring with a DP569 and DP562/4

If a DP570 is not available, it is possible to use a DP562 or DP564 along with both a DP569 and DP563 to perform similar monitoring functions. The setup shown in Figure 5-4 shows how this can be done when a DP562 is used. No external switching equipment is required, as either a serial remote connection, a GPI/O connection, or the front panel can be used to control the switching. However, due to the coding delay of the Dolby Digital process, the latency of this setup is greater than 200 ms and changes when switching between Dolby Digital and Dolby Surround.

When using the DP564 instead of a DP562, both the DP563 and DP569 can be connected directly to the multiple inputs on the unit.

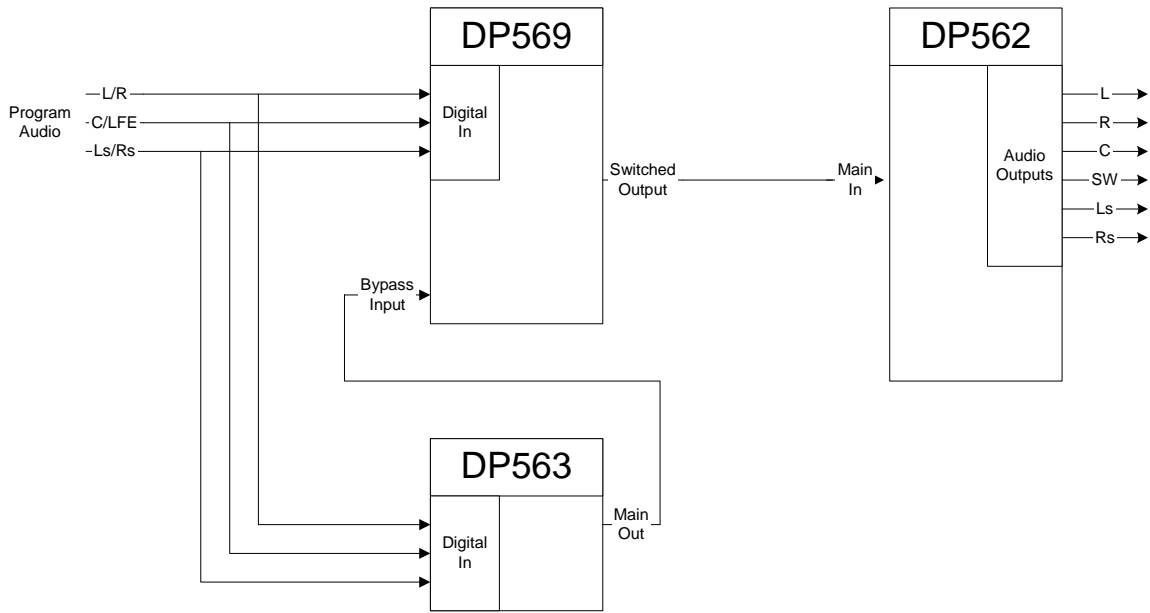

Figure 5-4 Dolby Digital/Surround Monitoring

5.2.3 Monitoring Content Ingest Using the LM100

The LM100 can log various errors in incoming linear PCM, analog, Dolby E, and Dolby Digital audio. Information that can be logged includes loudness levels, signal clipping, and audio silences.

Figure 5-5 shows a single LM100 being used to log either Dolby E audio from channels 3/4 or the analog output of tracks 1/2. Another example application would use two LM100s to simultaneously monitor the audio of both pairs of channels. Any errors could then be logged on a single PC.

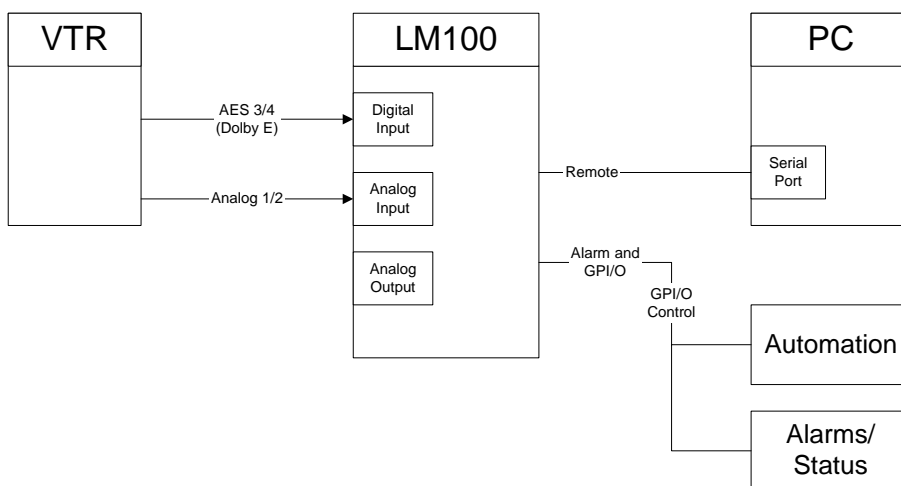

Figure 5-5 LM100 for Ingest Monitoring

5.2.4 Off-Air Monitoring with the LM100

The LM100 can be used for monitoring off-air signals and triggering an alarm via the installed station system to indicate that there may be a problem with the audio. The unit can be configured so that an alarm is triggered, for example, when the audio has been silent for a defined period of time, or if the loudness level is not within a defined threshold.

The optional RF tuner module is often used for this application.

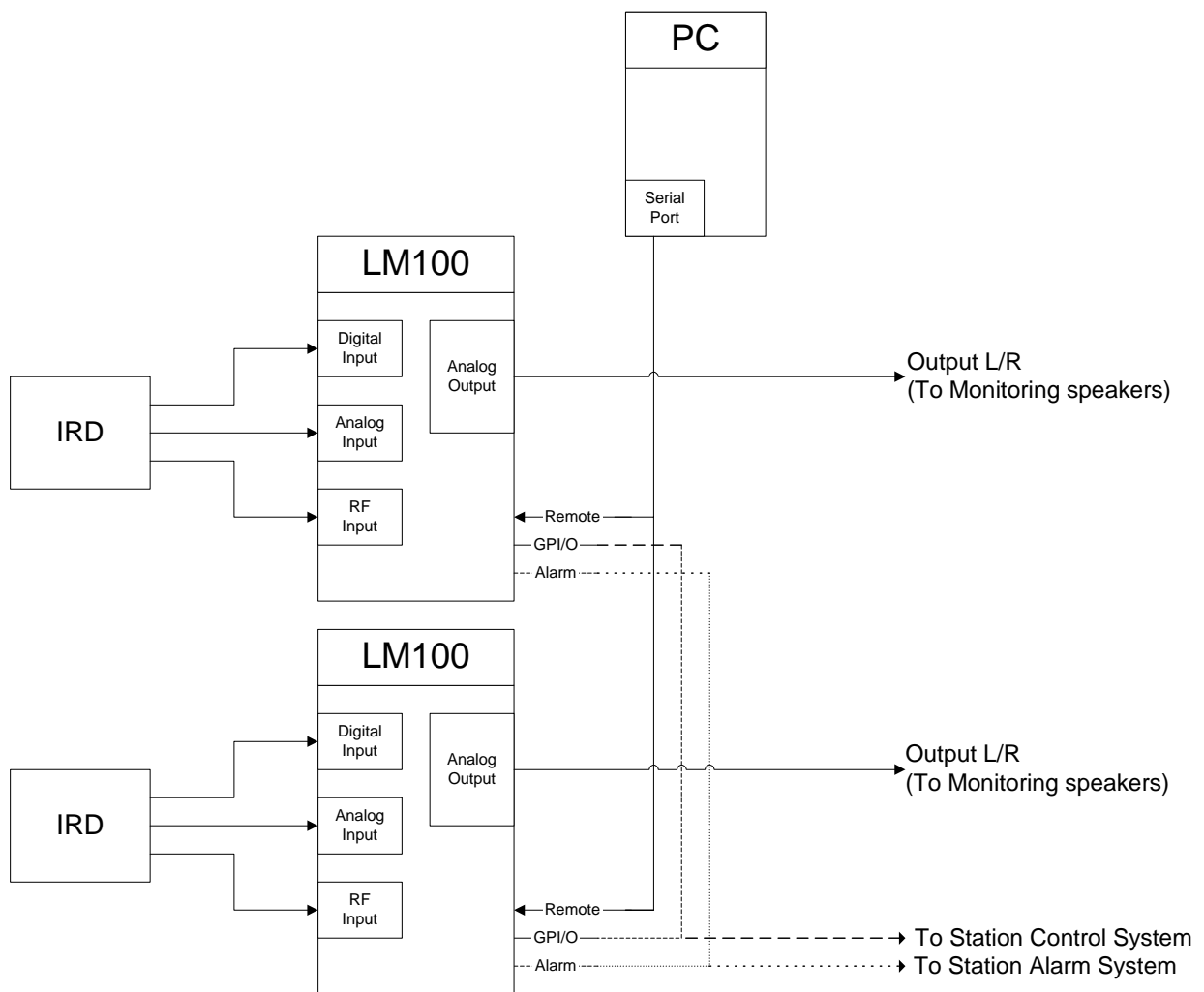

Figure 5-6 LM100 for Off-Air Analog Monitoring

Chapter 6

Serial Communications

These products all feature RS-485 and/or RS-232 connections. These can be used to upgrade the unit software or to control the operation of the unit. The electrical and mechanical specifications for these ports adhere to SMPTE 207M. The pin assignments for these connections are shown in the tables below. For information about the remote protocol, contact Dolby Laboratories.

6.1 RS-232 Ports

Table 6-1 shows the pin connections for the following units:

- DP562 serial I/O (female)
- DP572 auxiliary Data (male)

Table 6-1 Pin Connections for 9-Pin RS-232 Ports (DP562 and DP572)

Pin	Connection	Comment
1	DCD	Direct connection to DTR, DSR, and CTS
2	RX	Asynchronous data out
3	TX	Asynchronous data in
4	DTR	Direct connection to DCD, DSR, and CTS
5	GND	Signal ground
6	DSR	Direct connection to DCD, DTR, and CTS
7	NC	
8	CTS	Direct connection to DCD, DTR, and DSR
9	NC	

Table 6-2 shows the pin connections for the DP571 auxiliary Data port (female).

Table 6-2 Pin Connections for 9-Pin RS-232 Ports (DP571)

Pin	Connection	Comment
1	NC	
2	RX	Asynchronous data out
3	TX	Asynchronous data in
4	NC	
5	GND	Ground
6	NC	
7	NC	
8	CTS	Current limiting resistor to +5 V
9	NC	

RS-232 Using a Female 8-Pin Mini-DIN Connector

This connection is used for the front-panel remote connections.

Table 6-3 Pin Connections for 8-Pin RS-232 Ports

Pin	Connection	Comment
1	NC	
2	NC	
3	RX	Asynchronous data out
4	Ground	
5	TX	Asynchronous data in
6	NC	
7	NC	
8	Sense	Ground to select front-panel remote port

6.2 RS-485

Table 6-4 shows pin connection information for the following ports:

- Back-panel remote connections (except DP562)
- DP563 auxiliary data
- DP569 auxiliary data
- DP570 metadata input
- DP571 metadata input

Table 6-4 Pin Connections for RS-485 Ports (excluding Metadata Output)

Pin	Connection	Comment
1	Shield (chassis ground)	
2	TX A	Asynchronous data out –
3	RX B	Asynchronous data in +
4	Ground	
5	NC	
6	Ground	
7	TX B	Asynchronous data out +
8	RX A	Asynchronous data in –
9	Shield (chassis ground)	

Table 6-5 shows pin connection information for metadata output ports:

- DP570 metadata output
- DP572 metadata output

Table 6-5 Pin Connections for Metadata Output Ports

Pin	Connection	Comment
1	Shield (chassis ground)	
2	RX A	Asynchronous data in –
3	TX B	Asynchronous data out +
4	Ground	
5	NC	
6	Ground	
7	RX B	Asynchronous data in +
8	TX A	Asynchronous data out –
9	Shield (chassis ground)	

6.3 Metadata Connections

Metadata is data that relates to audio data. It is carried in both Dolby® E and Dolby Digital bitstreams.

The dialogue level is given here as an example of a metadata parameter. The dialogue level (dialnorm) value represents the average level of the audio. It is referenced to a level of digital full scale. It represents this average level even in a program that has no dialogue. As part of the Dolby Digital decoding process, the average level of the audio is reduced to –31 dBFS. If the dialogue level was set as –27 dBFS, then a 4 dB reduction is applied. This can be used to ensure that the decoded audio is kept at the

same level, and that a listener does not have to “gain ride” every time they change channels.

For further information about metadata, see *A Guide to Dolby Metadata*, or the *Dolby Digital Professional Encoding Guidelines*, available at www.dolby.com.

The DP569, DP570, and DP571 have metadata inputs; the DP570 and DP572 have metadata outputs. Connecting a metadata input to a metadata output requires a 9-pin male-to-male cable with direct connections between the pins. As metadata streams only flow in one direction, the cable only requires pins 3, 8, and ground to be connected. A metadata output can be connected to many metadata inputs. To do this, cables can be wired that have multiple connections to the output pins. An example application is shown in Figure 6-1. Each DP569 can be controlled by a separate set of parameters in the metadata stream. The set of parameters is referred to as a program.

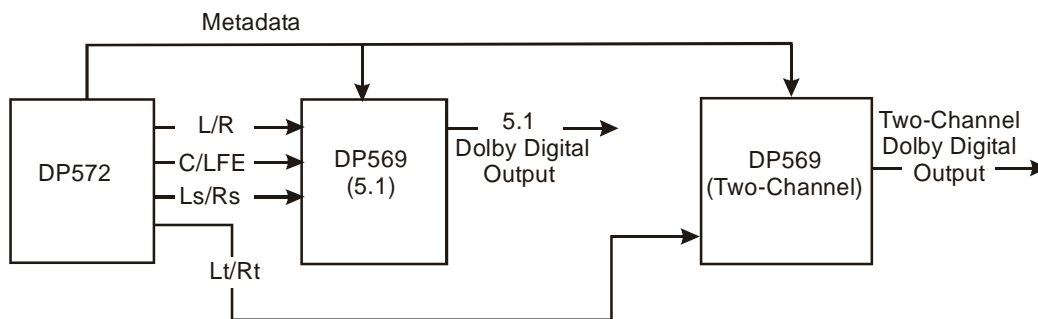

Figure 6-1 Metadata Multidrop

6.4 Serial Control

Serial control is available for a number of Dolby pro audio products. Each product requires that an address be assigned. The DP562 has a fixed address of 8282h. Other products allow selection of a valid address as detailed in SMPTE RP113-1996. For details of the serial control parameters of a particular model, please contact Dolby Laboratories.

When designing serial control systems for Dolby products, it is useful to have SMPTE RP113-1992 (*Supervisory Protocol for Digital Control Interface*) and SMPTE RP 138-1192 (*Control Message Architecture*) available for reference.