



# DM100 Bitstream Analyzer

## User's Manual



# DM100 Bitstream Analyzer

## LEDs



**Flashing Red:** Low battery



**Error**  
**Flashing Red:** Error counter changed  
**Red:** Error condition  
 See Error Stats menu, Section 3.2.8 for these functions

## PCM, Dolby Digital, Dolby E

**Green:** Receiving indicated input signal

**Flashing Green:** (equal on/off)  
 Decode Format setting does not match the input

**Flashing Green:** (long on)  
 AES3 channel status is being modified in Passthrough Mode. See Section 4.3.

## V Ref

**Green:** A valid video reference input signal is present, and unit is in a mode that requires it

**Off:** Current mode does not require a video reference

**Flashing Green:** Current mode requires a video reference and it is invalid or not present

## Mon

Resets internal settings to quickly allow monitoring of input bitstreams. Does not change output mode.

## Gen

Turns on generator, and displays bitstream select menu; pressing again generates next bitstream in list

## Setup

Switches display to top-level setup menu; use to set DM100 options

## Enter

Moves down one level in current menu item, or selects currently displayed option; also used to switch bottom line of LCD between graphic or numeric display from certain status menu items

## Status

Switches display to top-level status menu; shows details of input or output bitstream

## Power

Hold for two seconds to turn DM100 on or off

## Shift [LCD]

Momentarily enables or disables LCD backlight

## Shift [P1-P4]

Selects user-assigned custom presets

## Esc

Moves display up one level in menu tree, or aborts current operation

## Up/Down Buttons

Scroll through status or setup menu trees; changes settings

## Interface Connector

For test bitstream uploads, data logging, and firmware upgrades

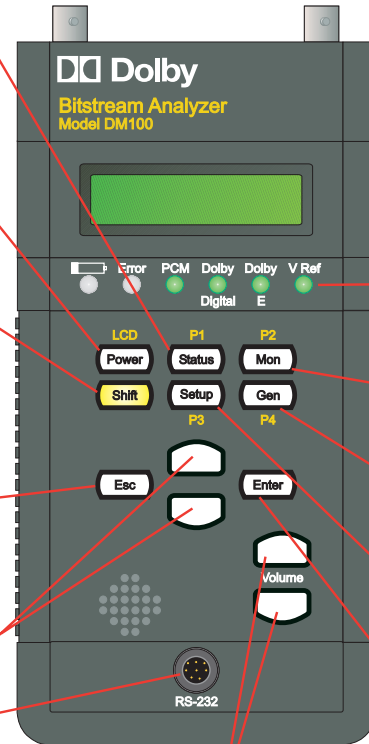

## Volume Buttons

Control level of speaker or headphone output (speaker is disabled when headphone is used)

## **Dolby Laboratories, Inc.**

### **Corporate Headquarters**

#### **Dolby Laboratories, Inc.**

100 Potrero Avenue

San Francisco, CA 94103-4813

Telephone 415-558-0200

Fax 415-863-1373

*www.dolby.com*

### **European Headquarters**

#### **Dolby Laboratories, Inc.**

Wootton Bassett

Wiltshire, SN4 8QJ, England

Telephone (44) 1793-842100

Fax (44) 1793-842101

Dolby and the double-D symbol are registered trademarks of Dolby Laboratories. Surround EX is a trademark of Dolby Laboratories. Toslink is a trademark of Toshiba Corporation. Windows is a registered trademark of Microsoft Corporation. All other trademarks remain the property of their respective owners.

© 2003 Dolby Laboratories Inc. All rights reserved.  
S03/13416/14616

Issue 2 Part No. 91751

---

## Table of Contents

### Chapter 1 Introduction

1.1 About the DM100.....	1-1
--------------------------	-----

### Chapter 2 Getting Started

2.1 Power.....	2-1
Battery Installation.....	2-1
[Power] Button.....	2-2
Battery Low LED.....	2-2
Auto-Power Off.....	2-2
2.2 Rear Belt Clip/Stand.....	2-3
2.3 Inputs.....	2-4
Dolby Digital.....	2-4
Dolby E.....	2-4
PCM.....	2-4
Other.....	2-4
Video.....	2-4
2.4 Outputs.....	2-5
Headphone Output.....	2-5
Speaker Output.....	2-5
2.5 Hookup.....	2-6
2.6 Quick Start.....	2-7
Making Your First Reading.....	2-7
Generating a Bitstream.....	2-7
2.7 Advanced Features.....	2-8
Measuring the Latency of Equipment.....	2-8
Measuring Audio/Video Frequency Drift ..	2-8

---

---

## Chapter 3 Operation: Status Mode

3.1	Main Status Screen .....	3-1
	Dolby E .....	3-2
	Dolby Digital .....	3-3
	PCM .....	3-3
	NULL Data .....	3-4
	Pause Data .....	3-4
	Data Type X .....	3-4
3.2	The Status Menus .....	3-5
3.2.1	Dolby E Metadata Input Menu .....	3-6
	Px Prog Desc .....	3-7
	Px Dialogue Lev .....	3-7
	Px Channel Mode .....	3-8
	Px LFE Channel .....	3-8
	Px Bitstrm Mode .....	3-8
	Px Line Mode Pro .....	3-9
	Px RF Mode Pro .....	3-9
	Px RF Ov Protect .....	3-9
	Px Center Dwnmx .....	3-10
	Px Srnd Dwnmx .....	3-10
	Px Dolby Srnd .....	3-10
	Px Mixing Level .....	3-11
	Px Room Type .....	3-11
	Px Copyright .....	3-11
	Px Orig Bitstrm .....	3-11
	Px Extnd Bitstrm .....	3-12
	Px DC Filter .....	3-13
	Px Lowpass Filt .....	3-13
	Px LFE Filter .....	3-13
	Px Srnd 3dB Attn .....	3-13
	Px Srnd Ph Shift .....	3-13
	Px Begin Gain .....	3-13
	Px End Gain .....	3-13

3.2.2	Dolby Digital Metadata Input Menu .....	3-14
	DD Dialogue Lev .....	3-15
	DD Channel Mode .....	3-15
	DD LFE Channel .....	3-15
	DD Data Rate .....	3-16
	DD Bitstrm Mode.....	3-16
	DD Line Mode Pro.....	3-17
	DD RF Mode Pro .....	3-17
	DD Center Dwnmx .....	3-17
	DD Srnd Dwnmx .....	3-18
	DD Dolby Srnd .....	3-18
	DD Mixing Level.....	3-18
	DD Room Type.....	3-19
	DD Copyright.....	3-19
	DD Orig Bitstrm.....	3-19
	DD Extnd Bitstrm .....	3-20
	DD Dual Mono MD .....	3-21
	DD Format .....	3-22
	DD Sample Rate.....	3-22
	DD Bitstream ID .....	3-22
	DD Stream #.....	3-23
3.2.3	AES3 Status Menu .....	3-24
3.2.4	Input Level Menu.....	3-26
3.2.5	Generator Status Display.....	3-27
3.2.6	Video Reference Status Display.....	3-28
3.2.7	Timecode Status Display.....	3-29
3.2.8	Error Stats Menu .....	3-30
3.2.9	DM100 Firmware Version .....	3-31

## **Chapter 4 Operation: Setup Mode**

Introduction .....	4-1
4.1 Monitor Control.....	4-2
4.2 Gen Control .....	4-4
4.3 AES3 Output .....	4-6
4.4 User Presets .....	4-8
4.5 I/O Control .....	4-9
4.6 System Settings .....	4-10

## **Chapter 5 Reference Information**

5.1 Data Transfer .....	5-1
Test Bitstream Loading .....	5-1
Data Logging .....	5-1
Firmware Upgrade .....	5-2
Data Transfer Error Messages.....	5-2
5.2 Unit Reset.....	5-3
Restore Default Settings .....	5-3
Hardware Reset.....	5-3
5.3 Connector Pinout Information.....	5-4
5.3.1 RS-232 Serial Port .....	5-4
5.3.2 XLR Connectors .....	5-4
5.3.3 Headphone Connector.....	5-4
5.4 DM100 Specifications.....	5-5
5.5 System Block Diagram.....	5-2

# Chapter 1

## Introduction

---

### 1.1 About the DM100

The Dolby® DM100 is a hand-held diagnostic tool that can monitor or generate Dolby Digital, Dolby E, and PCM bitstreams. The unit allows audio systems integrators and service engineers to quickly test the integrity and composition of these signals throughout a facility. The DM100 is intended for use in broadcast, cable, DBS, and postproduction facilities, as well as DVD mastering and home theater installation.

The DM100 accepts input signals via XLR, BNC, and Toslink™ connectors. The unit identifies the format of the input signal and activates the appropriate built-in decoder. The decoded analog signal, sent to a standard 1/8-inch stereo headphone jack, can be switched to monitor any two decoded channels, while a small built-in speaker can monitor the sum of any channel pair. A front-panel LCD displays Dolby Digital and Dolby E metadata information. Six front-panel LEDs indicate critical bitstream and system status information.

A set of Dolby Digital, Dolby E, and PCM test bitstreams is stored in internal, nonvolatile RAM, and can be changed in the field via software download. The selected test bitstream is produced simultaneously on all output connectors. The unit can receive and decode an input signal while simultaneously generating a test bitstream. The DM100 also features a pass-through mode that allows modification of the input signal's AES channel status bits before passing the signal to the output connectors. (The input signal can be monitored simultaneously.)

The DM100 also includes system level tests, such as latency measurements, and the ability to check the clock synchronization between audio and video signals.

---

---

# Chapter 2

## Getting Started

---

### 2.1 Power

The DM100 is powered by four standard AA 1.5 V batteries or from an external 6V, 800 mA DC power supply via the power input connector. The internal batteries are disconnected when the external DC power supply is used.

#### Battery Installation

Push the cover in the direction shown to slide it out.

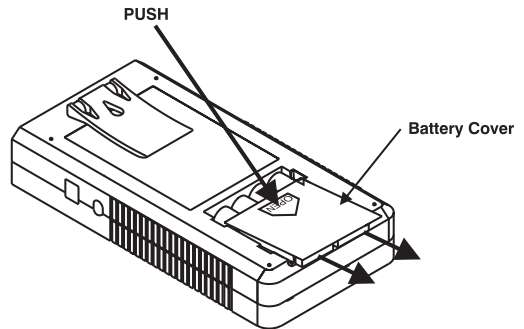

Insert four AA batteries, alternating the positive and negative terminals, and replace the cover.

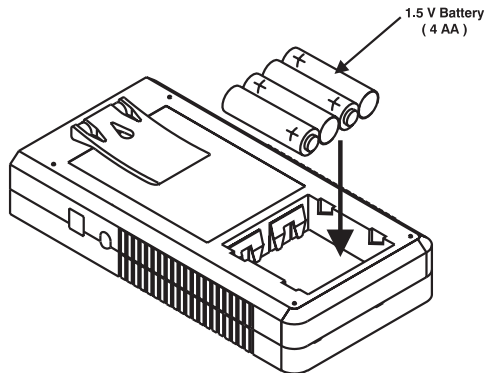

## [Power] Button

To turn on the DM100, press and hold the [Power] button down for two seconds. The display reads as shown for approximately one second while a self-test diagnostic runs.

Model DM100  
*Unit Name*

The power-on process ends with the DM100 operating in the last-used state. If the diagnostic test fails, the Error LED lights and an error message is displayed.

To turn off the DM100, press [Power] again. The display reads “Power Off” and the unit shuts off.

Power Off...

---

**Note:** Any changes made to the system settings may be lost if the unit is powered off by unplugging the external power supply, unless batteries are installed.

---

## Battery Low LED

The front-panel battery LED flashes when the batteries are nearly discharged. If the battery voltage drops below a usable level, the DM100 display reads “Dead Battery” and the unit shuts off.



Dead Battery...

## Auto-Power Off

When the DM100 is powered from batteries (external power supply not connected), the unit can be set to turn itself off after a selectable number of minutes with no user activity (5, 10, 15, or 30 minutes). This feature can be disabled. The factory default setting is 15 minutes.

The wait time is set from the Setup menu under System Settings, Power Management. See Section 4.6 for more information.

## External DC Power Supply

When powered from the external power supply, the Power Management setting is ignored and the unit remains switched on. The LCD backlight and keypad backlights are also enabled, overriding the LCD Backlight setting. See Section 4.6 for more information.

## 2.2 Rear Belt Clip/Stand

The pull-out clip on the rear of the DM100 can be used as a handy belt clip or a stand. Raise the clip by following these two steps:

1. Lift to release

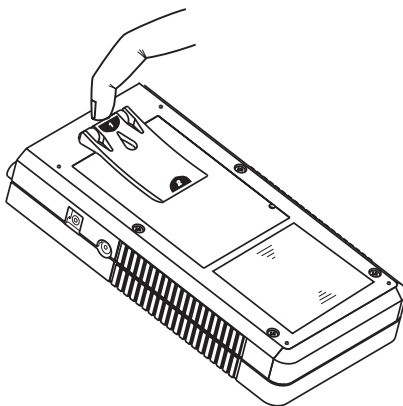

2. Pull up

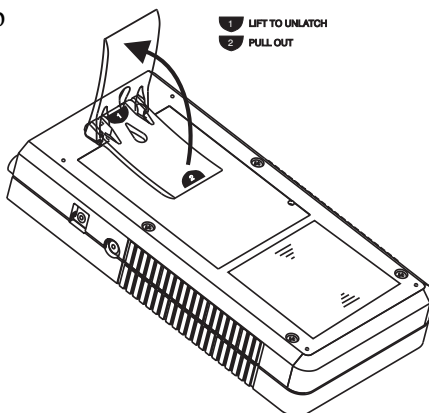

## 2.3 Inputs

Each input connector (XLR, BNC, or Toslink™) is active when specifically selected, or, if the input selection is set to autodetect, the first input with a valid AES3 signal becomes the active input. See Section 4.5 for setting the input select function. See the specifications in Section 5.4 for details on supported sample rates, impedances, and more.

The digital input format can be Dolby® Digital, Dolby E, or PCM.

### Dolby Digital

The DM100 accepts 16- and 32-bit Dolby Digital bitstreams. It also accepts AES3 data that contains multiple Dolby Digital bitstreams (i.e., one 16-bit mode bitstream in each AES3 channel).

### Dolby E

The DM100 accepts 16-, 20-, and 24-bit Dolby E bitstreams at NTSC (29.97 fps), PAL (25 fps), 23.98 fps, 24 fps, and 30 fps rates.

### PCM

If the input signal does not contain a header indicating that a pre-encoded bitstream is being received, the DM100 assumes the input signal is PCM audio.

### Other

The DM100 also accepts non-audio data over AES3. In this case, the LCD indicates that data is being received and the audio output mutes.

### Video

The unit can use an analog composite NTSC or PAL black burst reference video signal for signal generation, via the Ref Video RCA connector. The input is internally terminated at 75Ω.

## 2.4 Outputs

The XLR and BNC output connectors are always active. The Toslink connector is enabled when it is selected.

The digital output signal can be:

Pass-through Dolby Digital, Dolby E, or PCM.

*The output clock is locked to the digital input.*

Or

An internally generated Dolby Digital, Dolby E, or PCM test bitstream.

*The output clock can be locked to an internal 48 kHz clock, a digital input signal, or to 48 kHz derived from the video reference input. See Section 4.5 for more information.*

### Headphone Output

The headphone output is used to monitor the decoded Dolby Digital, Dolby E, or PCM signal. Front-panel buttons adjust the headphone volume.

### Speaker Output

The speaker output is used to monitor the decoded Dolby Digital, Dolby E, or PCM signal when headphones are not being used. The signal is a mono version of the headphone output. Front-panel buttons adjust the speaker volume.

---

**Note:** When listening to Dolby Digital bitstreams on the speaker output, RF Mode compression is always applied, regardless of the DD Compression setting in the Monitor Control Setup menu. See Section 4.1 for more information.

---

## 2.5 Hookup

Figure 2-1 shows the locations for connecting components to the DM100.

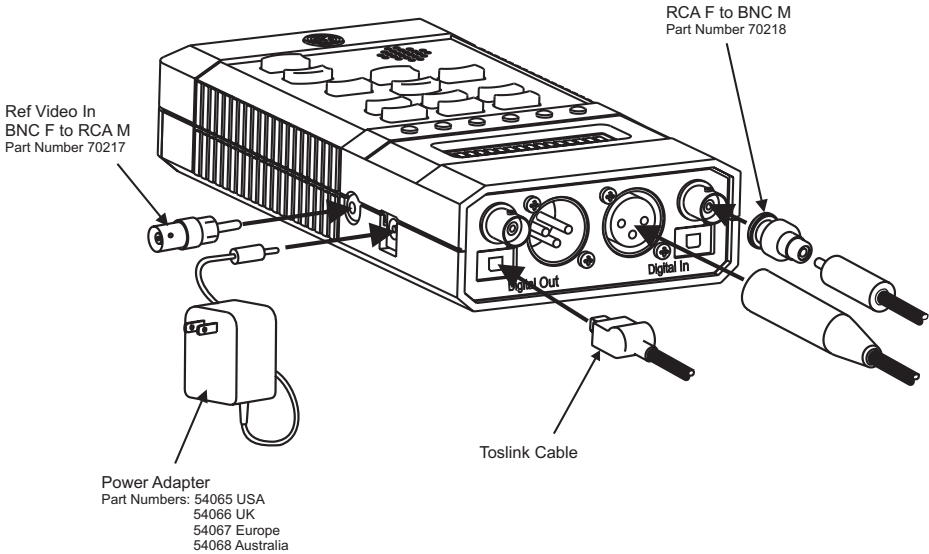

**Figure 2-1** Connections

**Note:** References to the front-panel buttons are shown using brackets throughout this manual (e.g., “[Status]”). References to multiple-button combinations mean sequences, not simultaneous button presses. Press the first button, release, and then press the next button.

## 2.6 Quick Start

The DM100 is designed to be easy and intuitive to use. Follow these simple procedures to begin taking your first readings and generating your first test streams.

### Making Your First Reading

1. Turn on the unit by pressing [Power].
2. Connect the input signal to the appropriate connector.
3. Press [Mon]. This resets all the internal monitoring setup functions to the defaults.

The LEDs should display the signal type received, and the display shows information about the incoming signal. If you cannot see this information, press [Status], then use [Enter], [Esc], and the [Up/Down] buttons to navigate through the status menus to view information about the incoming signal. See Section 3.2 for additional information.

Adjust the audio level with the dedicated [Volume] buttons.

### Generating a Bitstream

1. Press [Gen] once. This turns the generator on and outputs a PCM test signal.
2. To select other test streams, continue to press [Gen].

Different clock sources can be used for the generator; these can be selected in the Gen Clock Source menu:

Setup / I/O Control / Gen Clock Source

See Section 4.5 for more information.

To read the current status of the generator, press [Status] and navigate using the [Down] button until **Generator Enter to View** is displayed. Press [Enter] to see the current settings. See Section 3.2.5 for more information.

You can even connect the output of the DM100 to the input. Doing this allows you to listen to the test stream and view all of the streams' settings.

## 2.7 Advanced Features

### Measuring the Latency of Equipment

The DM100 can be used to measure the latency of other audio equipment. At user-defined intervals, the DM100 generates a short burst of white noise, then measures the time taken for the signal to return.

Set the DM100 to measure latency by following these steps:

1. Go to the Gen Control / Output Mode setup menu, and select Latency Test (see Section 4.2).
2. Connect the Digital Out from the DM100 to the equipment to be measured.
3. Connect the output of the equipment to be measured to the DM100's Digital Input.

Different clock sources used for the generator can be set in the I/O Control / Gen Clock Source setup menu (see Section 4.5).

The time interval between the noise bursts can be set in the Gen Control / Noise Burst Rate setup menu (see Section 4.2).

To read the measured latency, press [Status] and navigate using the [Down] button until **Generator ENTER to View** is displayed. Press [Enter] to display the measured latency in either AES samples or milliseconds (see Section 3.2.5).

### Measuring Audio/Video Frequency Drift

The DM100 determine if an AES digital audio or reference signal is frequency-locked to a video black burst reference signal. The unit locks to the video reference, then measures the frequency difference between the Digital In input and the video reference.

Set the unit to measure frequency drift as follows:

1. Go to the Gen Control / Output Mode setup menu, and select A/V Freq Drift (see Section 4.2).
2. Connect a 29.97 or 25 fps video reference to DM100's V Ref input.
3. Connect the test AES signal to the DM100's Digital In.

Read the measured frequency drift between the AES and video signals by pressing [Status] and then navigating using the [Down] button until **Generator / Enter to View** is displayed. Press [Enter] to read the measured frequency drift (see Section 3.2.5). The display indicates frequency difference in AES samples: a positive number indicates the AES input signal is faster than the video reference. Therefore, if the two signals are locked, the display will read "0 samples." Pressing [Enter] resets the counter.

### **Modifying the Pass Through Output Signal**

The DM100 can be used to repair improperly authored audio streams. When in Pass Through mode, the DM100 can modify channel status bits in the first and third bytes of the AES3 signal. In addition, the output audio channels can be skewed or swapped to correct improper channel alignment (see Section 4.5).

# Chapter 3

## Operation: Status Mode

After power-on, the DM100 defaults to Status mode, with the top-level main status screen displayed. Status mode is used for displaying, monitoring, and analyzing the input bitstream.

**Note:** References to the front-panel buttons are shown using brackets throughout this manual (e.g., “[Status]”). References to multiple-button combinations mean sequences, not simultaneous button presses. Press the first button, release, and then press the next button.

### 3.1 Main Status Screen

The main status screen is the top level of the status menu tree. It displays one of the following possible combinations of information. The display shown below gives a typical example:

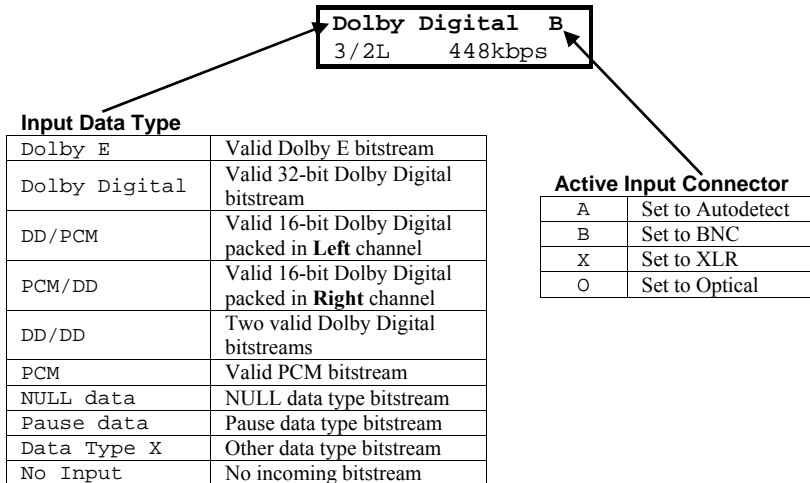

The following pages describe the information displayed on the second line for each type of input data.

## Dolby E

When the incoming bitstream is Dolby® E, the following information will be displayed:

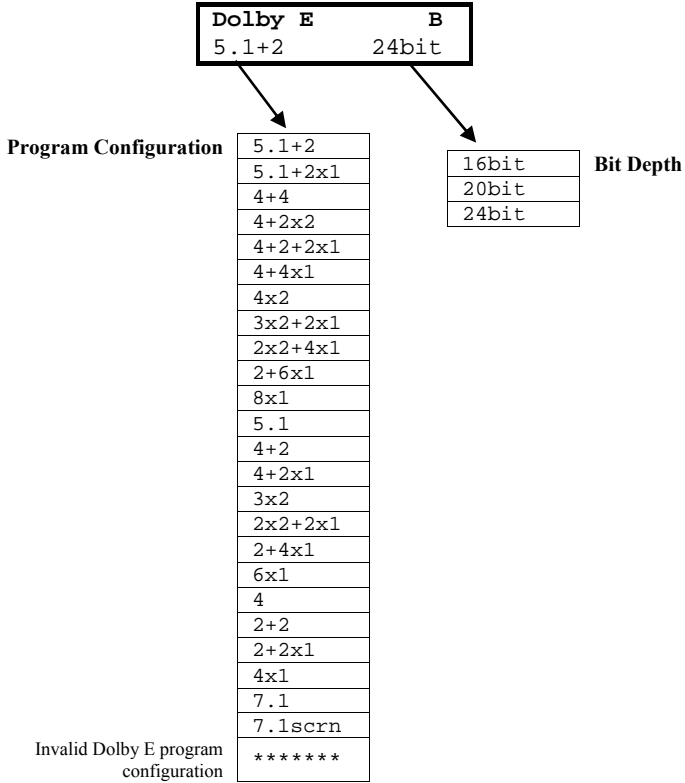

## Dolby Digital

When the incoming bitstream is Dolby Digital, the following information will be displayed:

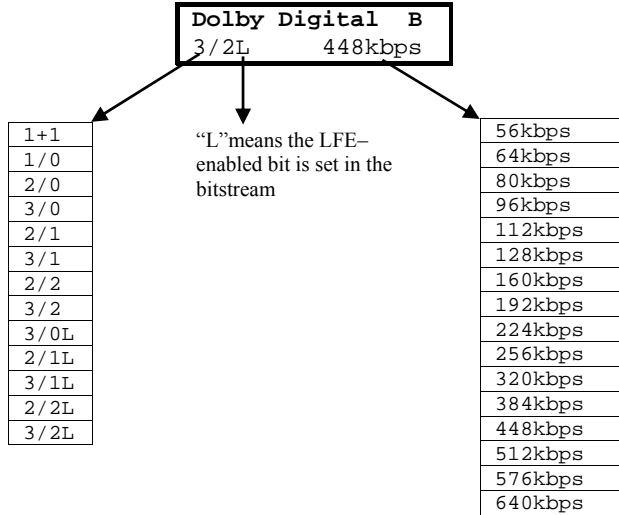

## PCM

When the incoming bitstream is PCM, and the DM100 has locked to it, the following information will be displayed:

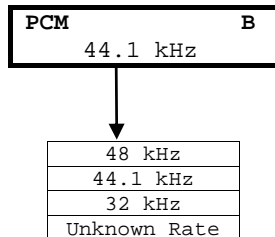

### **NULL Data**

When the incoming bitstream is Null data, as defined in the IEC 61937 or SMPTE 337M standards, the following screen is displayed:



**NULL data**

### **Pause Data**

When the incoming bitstream is Pause data, as defined in the IEC 61937 standard, the following screen is displayed:



**PAUSE data**

### **Data Type X**

When the data type of the incoming bitstream is not recognized as one of the preceding types, the following screen is displayed:

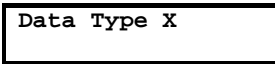

**Data Type X**

## 3.2 The Status Menu

From the top-level main Status display described above, you can step through the **status menus** by pressing the [Up] or [Down] button. Each menu below the top main Status display is described in the following manual sections.

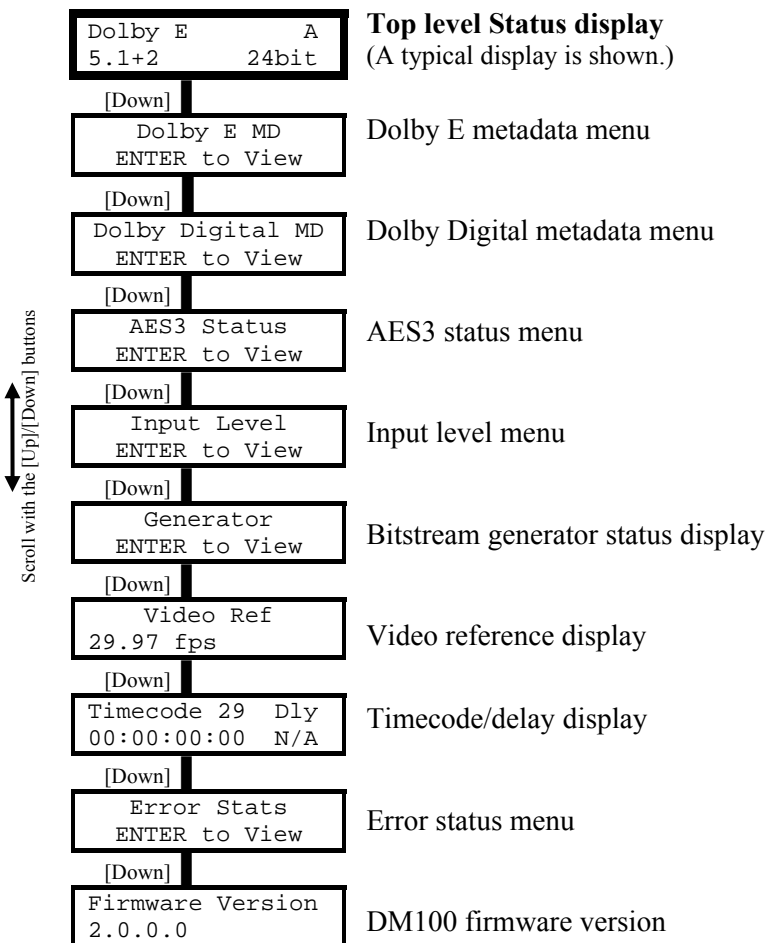

### 3.2.1 Dolby E Metadata Input Menu

After pressing [Enter] to view this menu, press the [Down] or [Up] button to select the submenu options you wish to display.

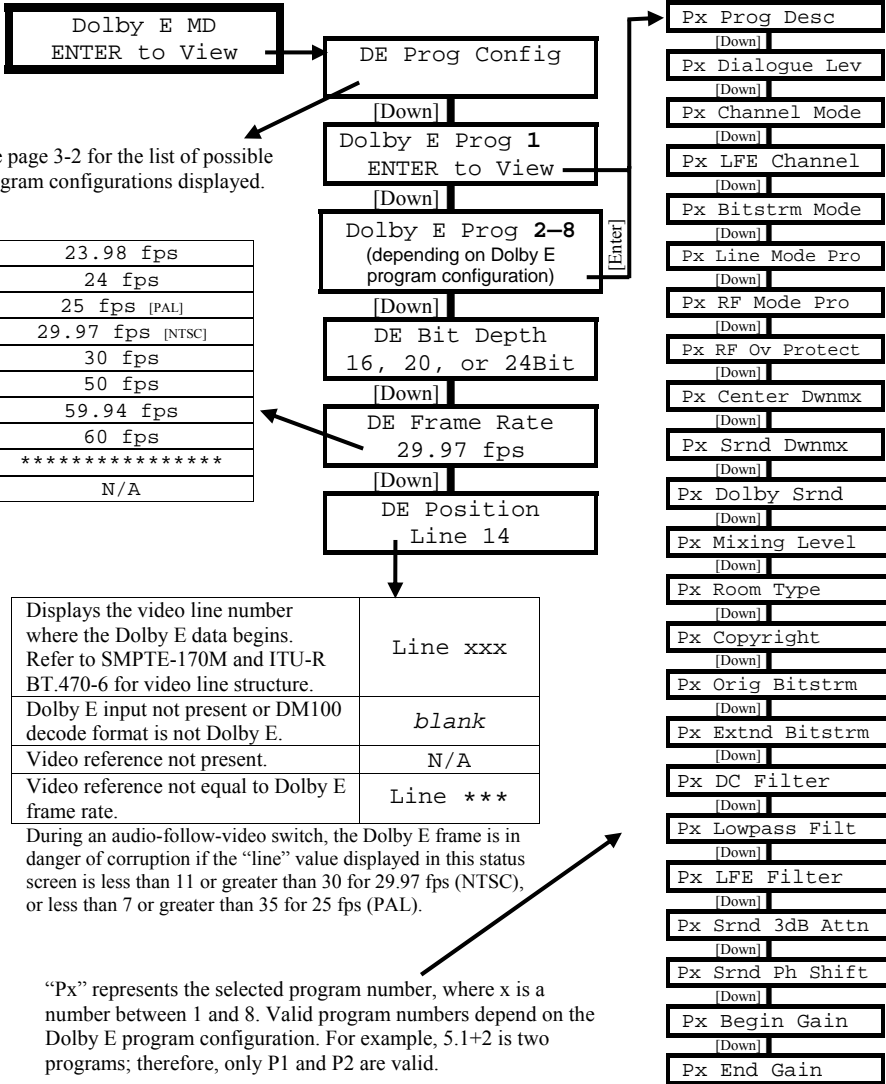

During an audio-follow-video switch, the Dolby E frame is in danger of corruption if the “line” value displayed in this status screen is less than 11 or greater than 30 for 29.97 fps (NTSC), or less than 7 or greater than 35 for 25 fps (PAL).

“Px” represents the selected program number, where x is a number between 1 and 8. Valid program numbers depend on the Dolby E program configuration. For example, 5.1+2 is two programs; therefore, only P1 and P2 are valid.

Each metadata program parameter selection is described in the following sections.

## Px Prog Desc

Dolby E program description display:

Px Prog Desc <i>Description text</i>
---

The DM100 has a 32-character buffer for each program, which stores the first characters in the description text field for that program. The display scrolls through the text automatically if the string is greater than 16 characters.

## Px Dialogue Lev

A typical example is shown for the Dolby E Dialogue Normalization display:

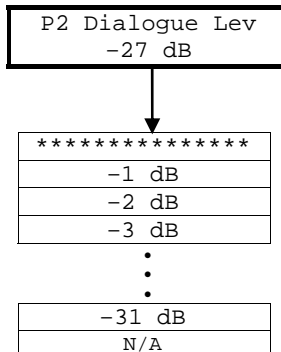

## Px Channel Mode

A typical example is shown for the Dolby E Channel Mode display:

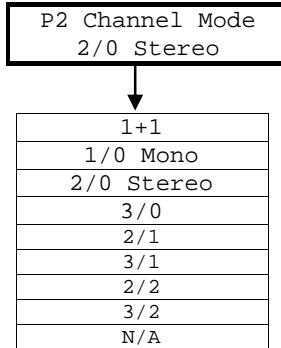

## Px LFE Channel

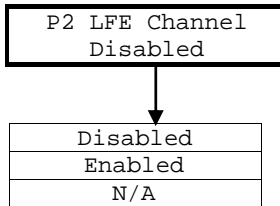

## Px Bitstrm Mode

A typical example is shown for the Dolby E Bitstream Mode display:

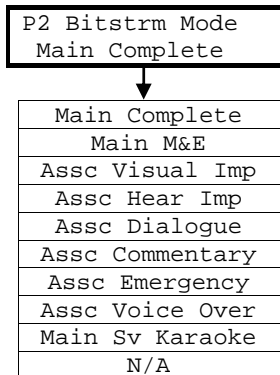

## Px Line Mode Pro

### Px RF Mode Pro

The Dolby E Line Mode and RF Mode Profile program parameters display the same second-line display.

A typical example is shown for the RF Mode Profile display:

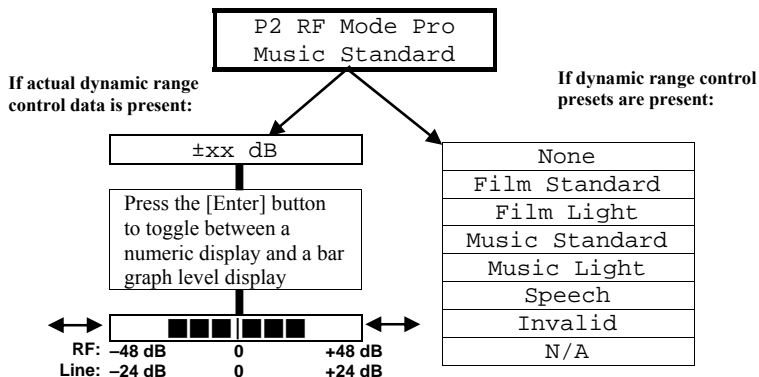

### Px RF Ov Protect

RF overmodulation protection.

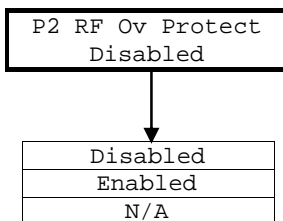

### Px Center Dwnmx

A typical example is shown for the Dolby E Center Downmix display:

P2 Center Dwnmx 0.500 (-6.0 dB)
↓
0.707 (-3.0 dB)
0.596 (-4.5 dB)
0.500 (-6.0 dB)
*****
N/A

### Px Srnd Dwnmx

A typical example is shown for the Dolby E Surround Downmix display:

P2 Srnd Dwnmx 0.707 (-3.0 dB)
↓
0.707 (-3.0 dB)
0.500 (-6.0 dB)
0 (-999 dB)
*****
N/A

### Px Dolby Srnd

A typical example is shown for the Dolby E Surround Mode display:

P2 Dolby Srnd Not Indicated
↓
Not Indicated
Not Dolby Srnd
Dolby Srnd
*****
N/A

## Px Mixing Level

A typical example is shown for the Dolby E Mixing Level display:

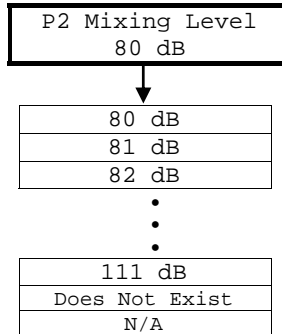

## Px Room Type

A typical example is shown for the Dolby E Room Type display:

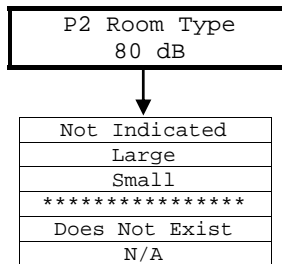

## Px Copyright

### Px Orig Bitstrm

A typical example is shown for the Dolby E Copyright display. The Original Bitstream program parameters display the same second line:

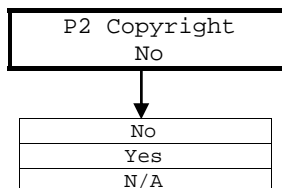

### Px Extnd Bitstrm

A typical example is shown for the Extended Bitstream metadata display. Other possibilities are also shown:

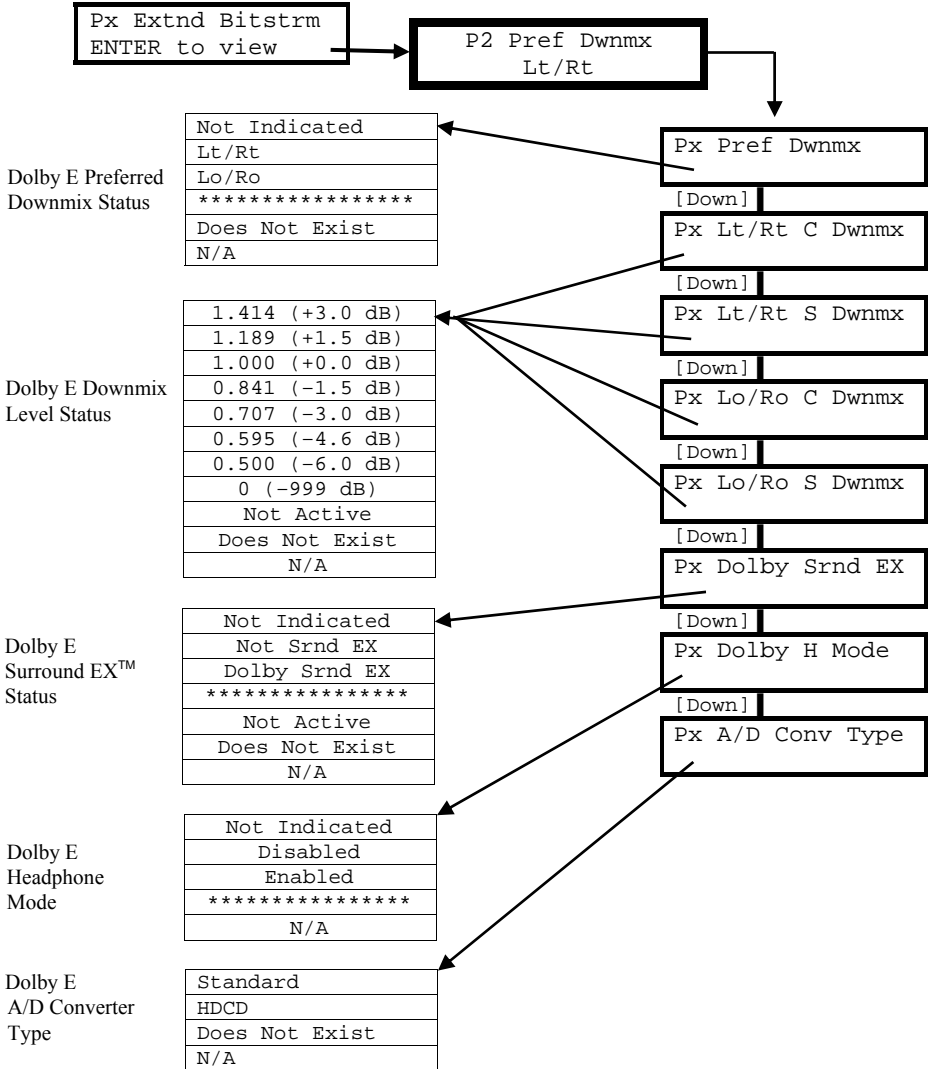

- Px DC Filter**
- Px Lowpass Filt**
- Px LFE Filter**
- Px Srnd 3dB Attn**
- Px Srnd Ph Shift**

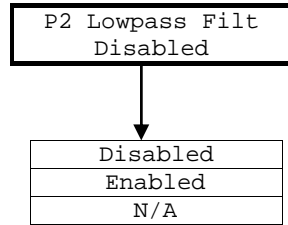

When any of these Dolby E metadata programs is selected, the DM100 displays the same information as shown in the example. A typical example is shown for the Dolby E Lowpass Filter display.

**Px Begin Gain**  
**Px End Gain**

A typical example is shown for the Dolby E Begin Gain and End Gain display:

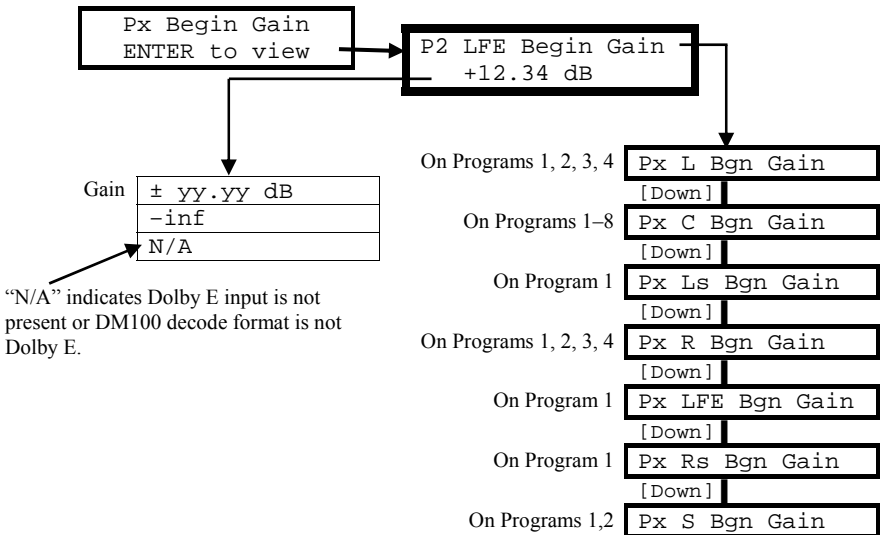

### 3.2.2 Dolby Digital Metadata Input Menu

After pressing [Enter] to select this function, press the [Down] or [Up] button to select the parameter you wish to display.

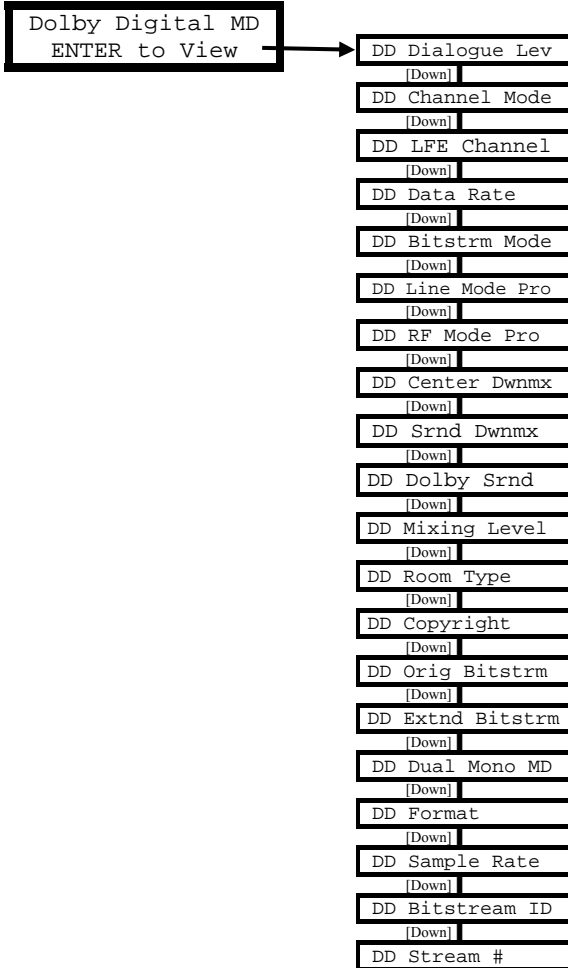

Each Dolby Digital metadata parameter display is described in the following manual sections.

### DD Dialogue Lev

A typical example is shown for the Dolby Digital Dialogue Normalization Status display:

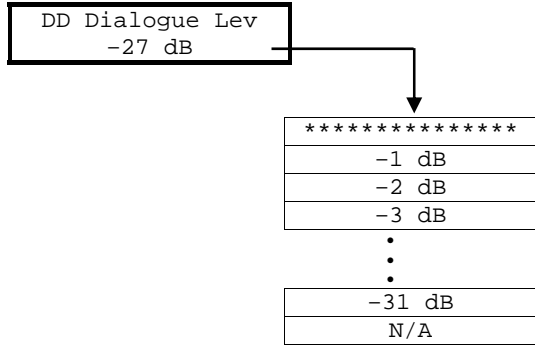

### DD Channel Mode

A typical example is shown for the Dolby Digital Channel Mode display:

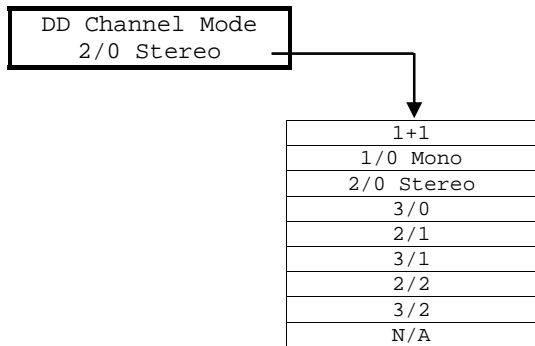

### DD LFE Channel

A typical example is shown for the Dolby Digital LFE Status display:

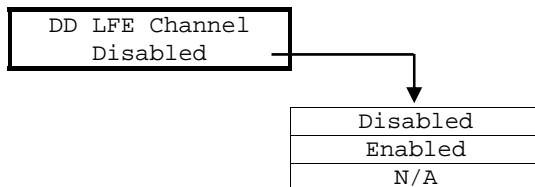

## DD Data Rate

A typical example is shown for the Dolby Digital Data Rate display:

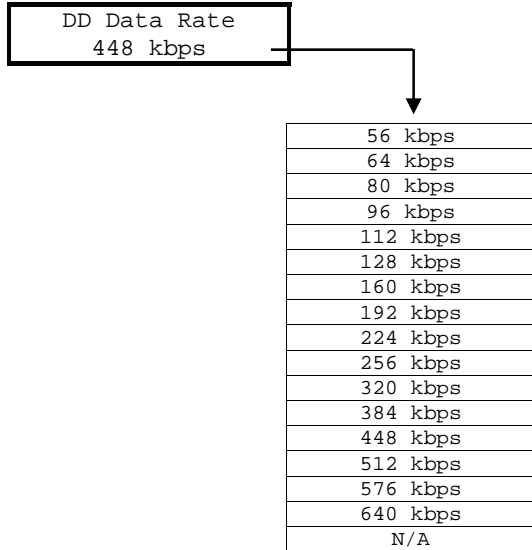

## DD Bitstrm Mode

A typical example is shown for the Dolby Digital Bitstream Mode display:

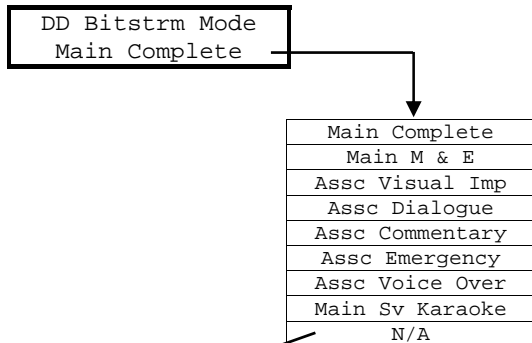

“N/A” indicates that a Dolby Digital input is not present, or the DM100 decode format is not Dolby Digital.

## DD Line Mode Pro

## DD RF Mode Pro

The Dolby Digital Line Mode and RF Mode Profile parameters use the same display style.

A typical example is shown for the RF Mode Profile display:

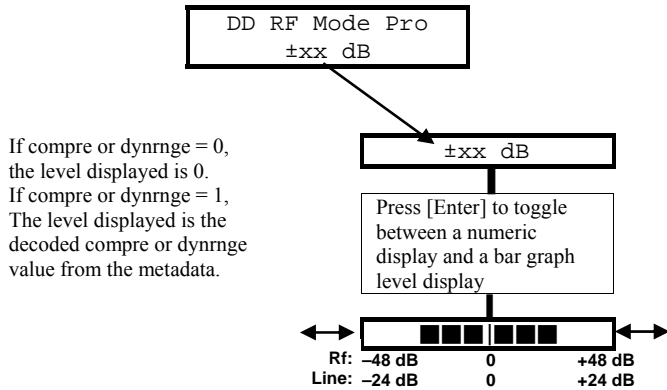

## DD Center Dwnmx

A typical example is shown for the Dolby Digital Center Downmix display:

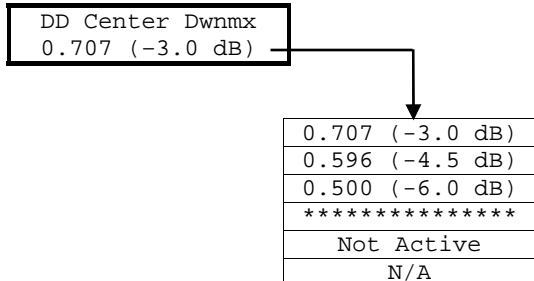

### DD Srnd Dwnmx

A typical example is shown for the Dolby Digital Surround Downmix display:

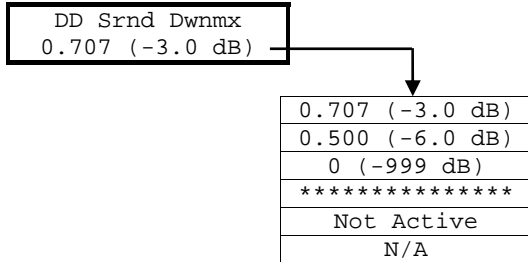

### DD Dolby Srnd

A typical example is shown for the Dolby Digital, Dolby Surround Mode display:

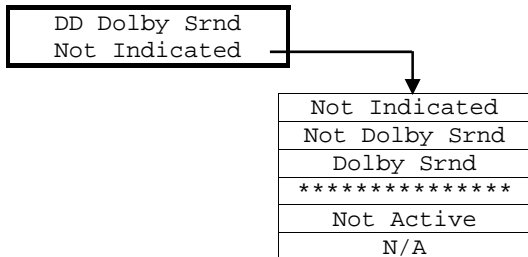

### DD Mixing Level

A typical example is shown for the Dolby Digital Mixing Level status display:

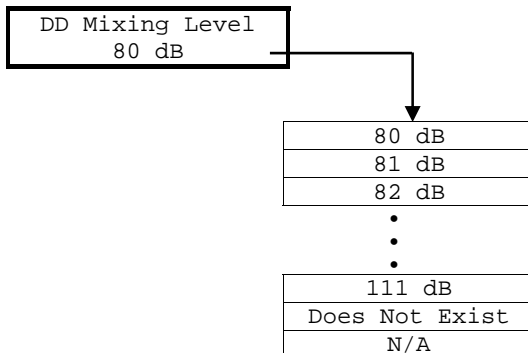

### DD Room Type

A typical example is shown for the Dolby Digital Room Type display:

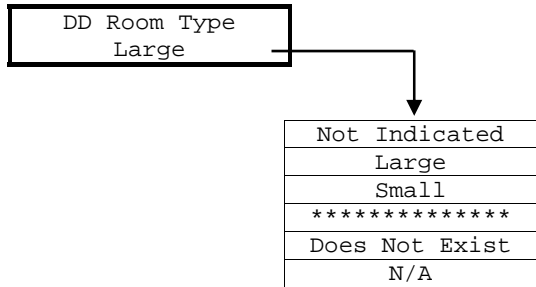

### DD Copyright

#### DD Orig Bitstrm

A typical example is shown for the Dolby Copyright status display. The Original Bitstream program parameters display the same second line:

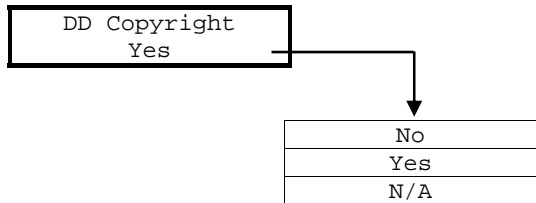

### DD Extnd Bitstrm

A typical example is shown for the Extended Bitstream information display. Other possibilities are shown:

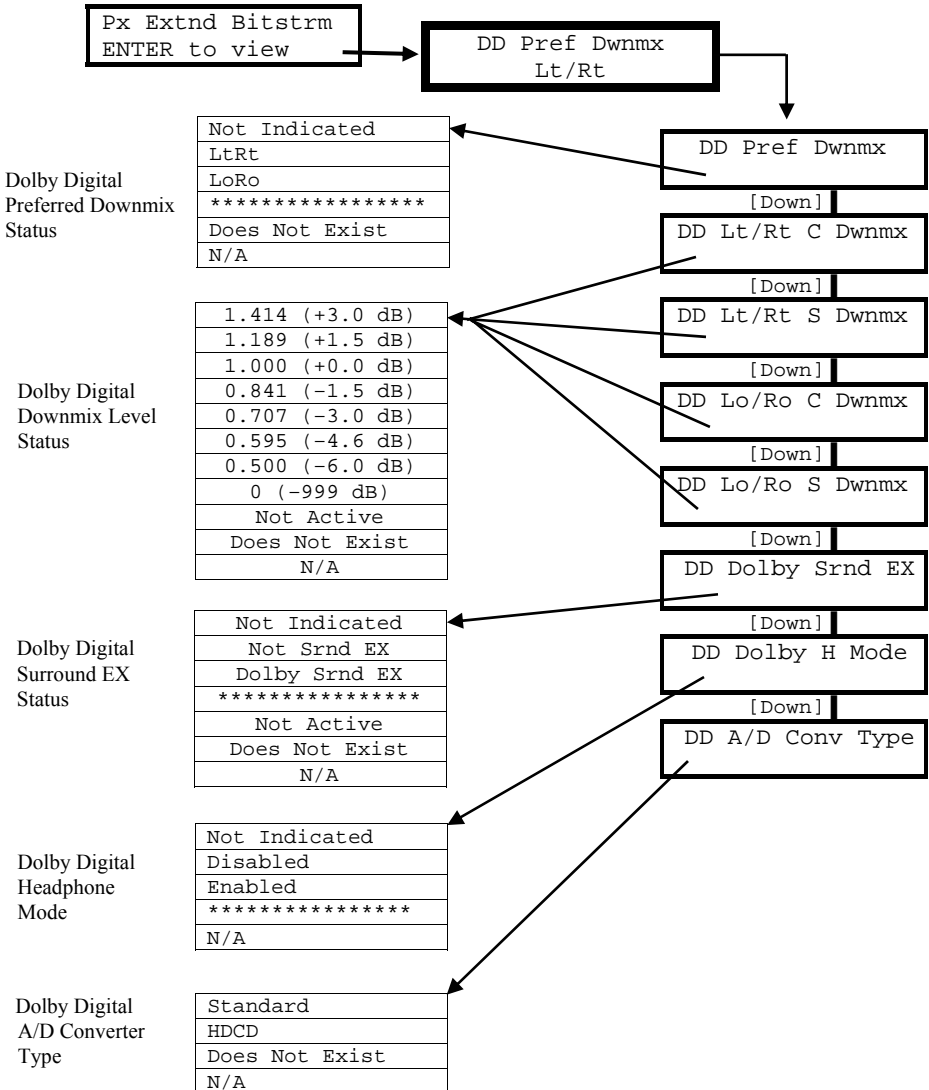

### DD Dual Mono MD

After pressing [Enter] to select this function, press the [Down] or [Up] button to select the Dual Mono metadata parameter you wish to display. A typical example screen is shown:

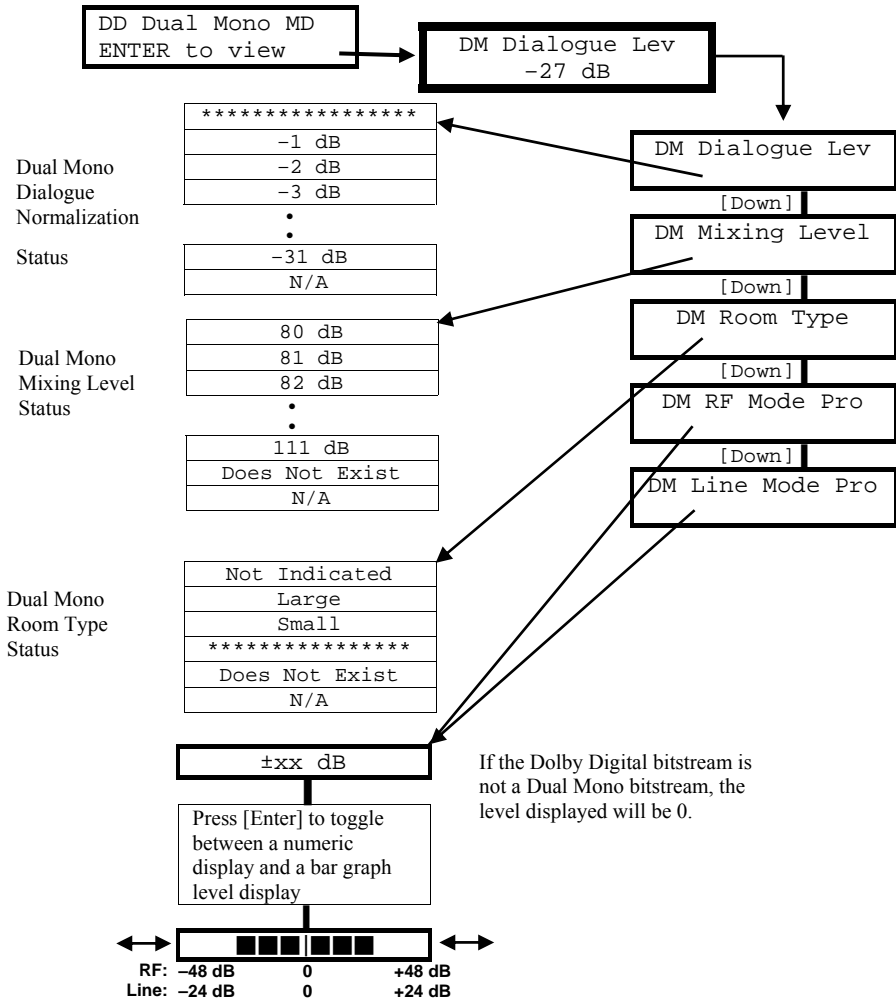

## DD Format

A typical example is shown for the Dolby Digital Format status display:

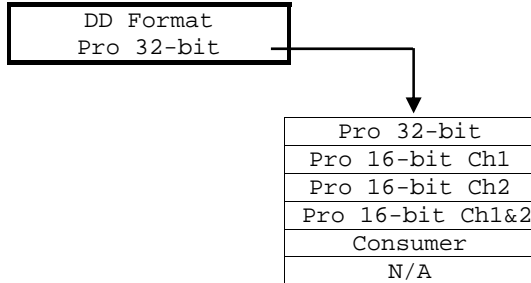

## DD Sample Rate

A typical example is shown for the Dolby Digital Sample Rate status display:

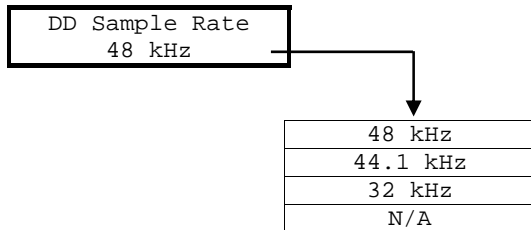

## DD Bitstream ID

A typical example is shown for the Dolby Digital Bitstream ID status display:

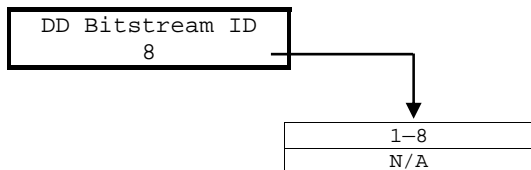

**DD Stream #**

A typical example is shown for the Dolby Digital Stream Number status display:

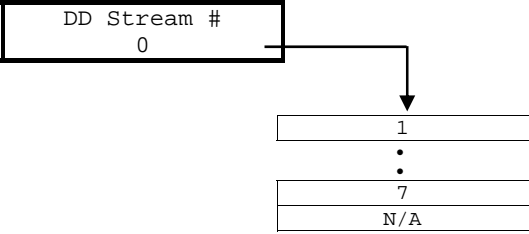

### 3.2.3 AES3 Status Menu

After pressing [Enter] to select this menu, press the [Down] or [Up] button to select the AES3 parameter you wish to display. A typical example screen is shown:

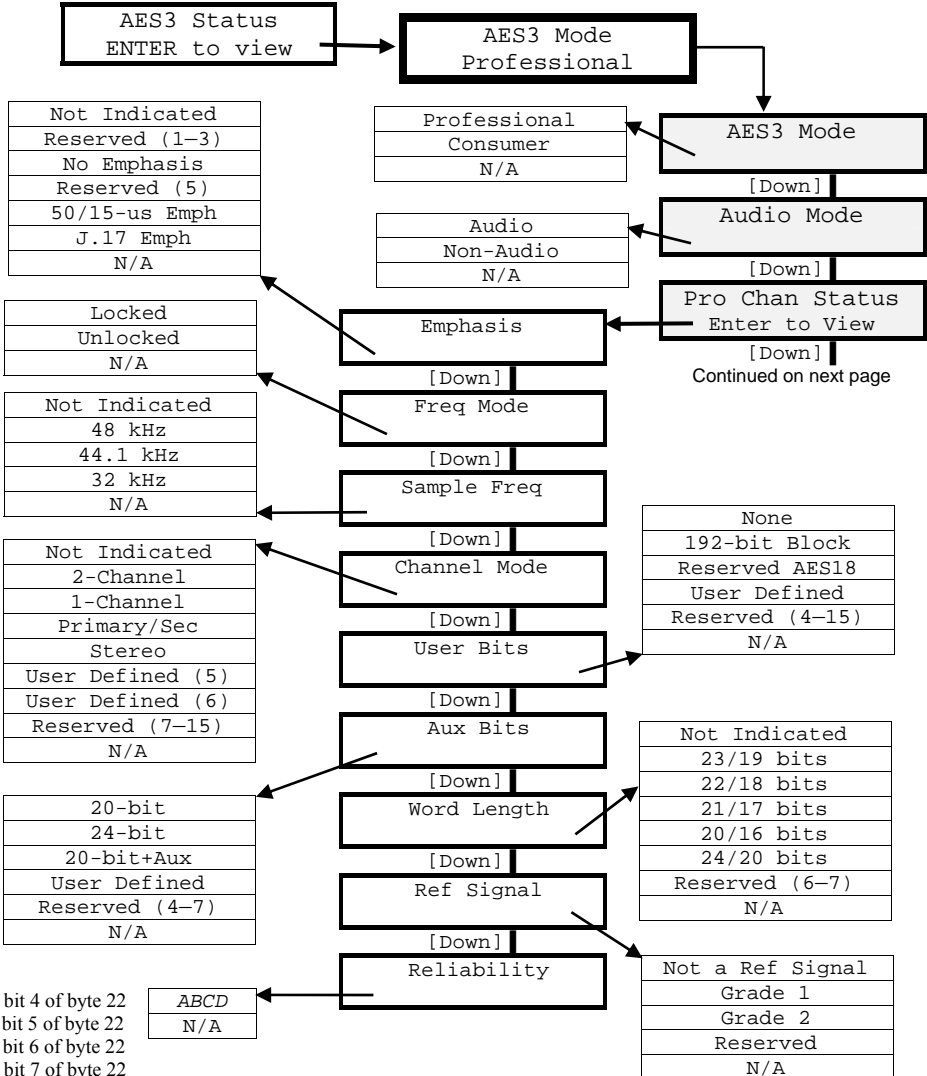

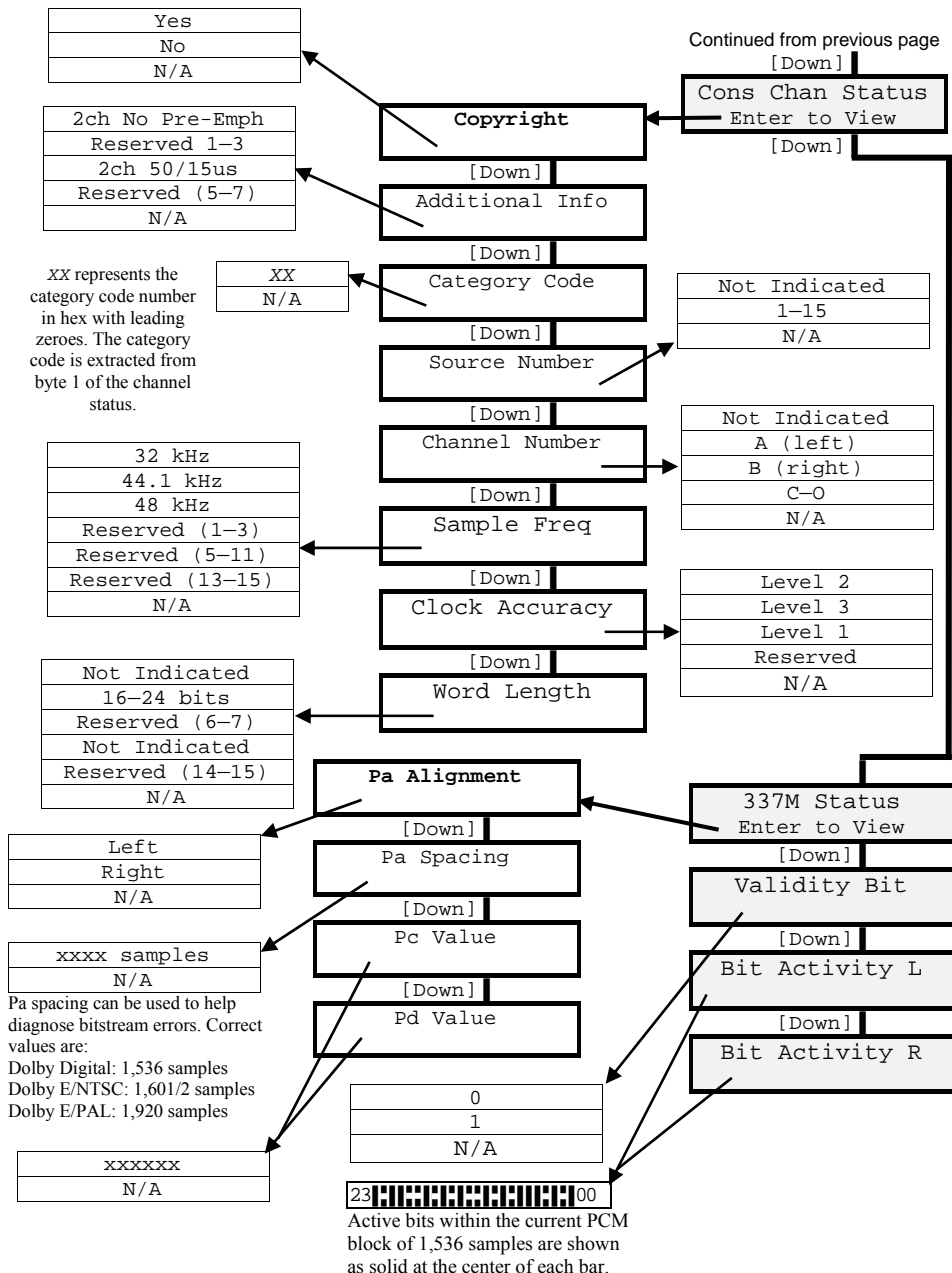

### 3.2.4 Input Level Menu

Press [Enter] to display Input Level status. The display combinations are shown below. A typical example screen is shown:

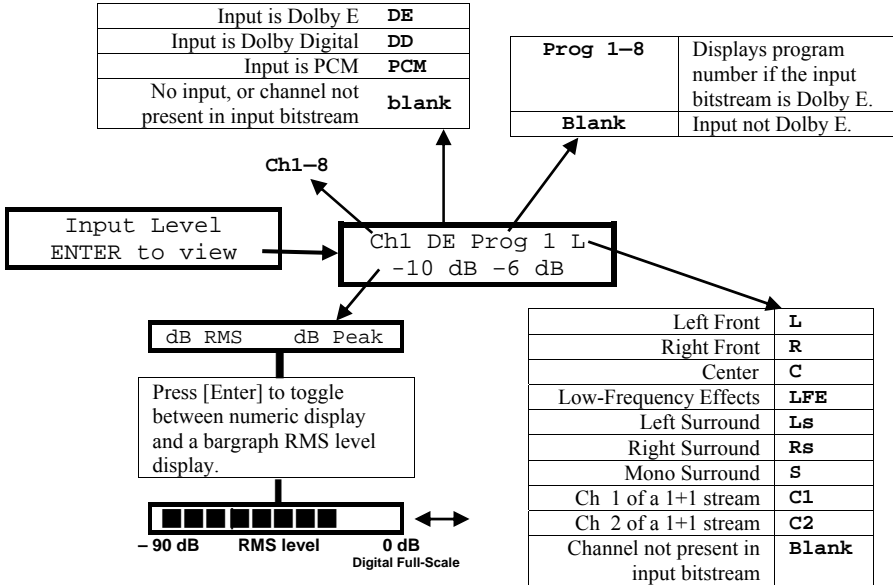

### 3.2.5 Generator Status Display

Press [Enter] to display Generator status. The possible display combinations are shown below:

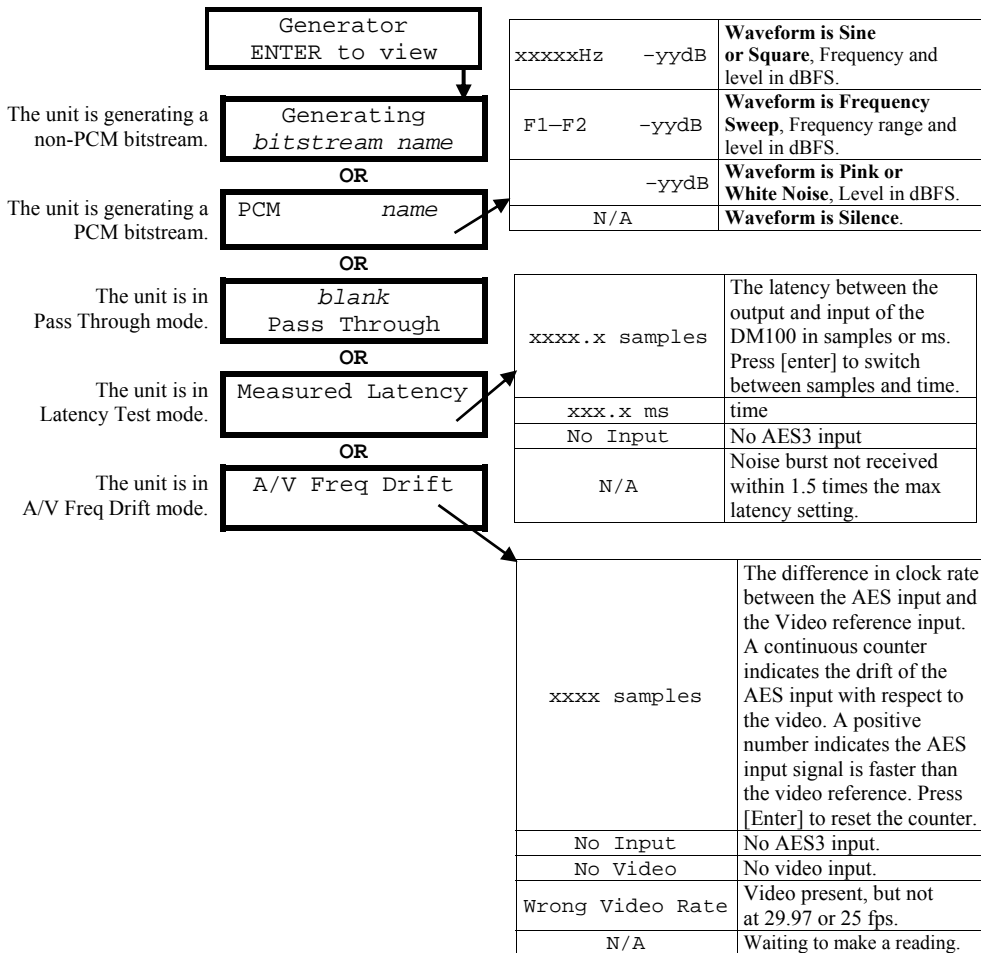

See Section 4.2 for selecting stream and waveform names and frequencies.

### 3.2.6 Video Reference Status Display

A typical example is shown for the Video Reference input status display:

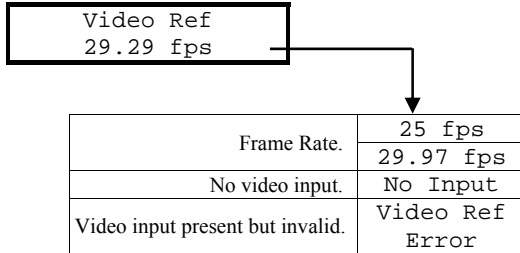

### 3.2.7 Timecode Status Display

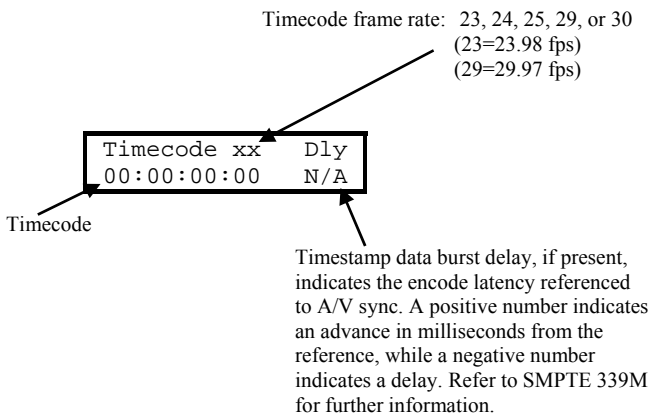

#### Dolby Digital

Timecode data as derived from the timestamp of the stream currently being decoded (if present). Encoding latency can be conveyed to a downstream MPEG broadcast encoder with a Dolby Digital stream.

Semicolons are used to separate the timecode fields when receiving Drop Frame timecode.

#### Dolby E

Timecode data as carried within the Dolby E bitstream, derived from the metadata.

“\*\*:\*\*:\*\*:\*\*:\*\* N/A”

The display shown above occurs under any of the following conditions:

- A Dolby E or Dolby Digital bitstream is not being decoded (this includes selecting the PCM portion of a 16-bit Dolby Digital/PCM stream).
- The current Dolby E timecode field is set to “invalid” or the Dolby Digital bitstream does not contain timecode.

### 3.2.8 Error Stats Menu

After pressing [Enter] to select the Error Statistics menu, press the [Down] or [Up] button to select the desired error screen. A typical example screen is shown.

The first screen displays any current error condition that prevents correct operation of the DM100. Subsequent screens display a historical count of errors. Error counts over 99 display as 99. Press [Enter] to reset a displayed error count to 00.

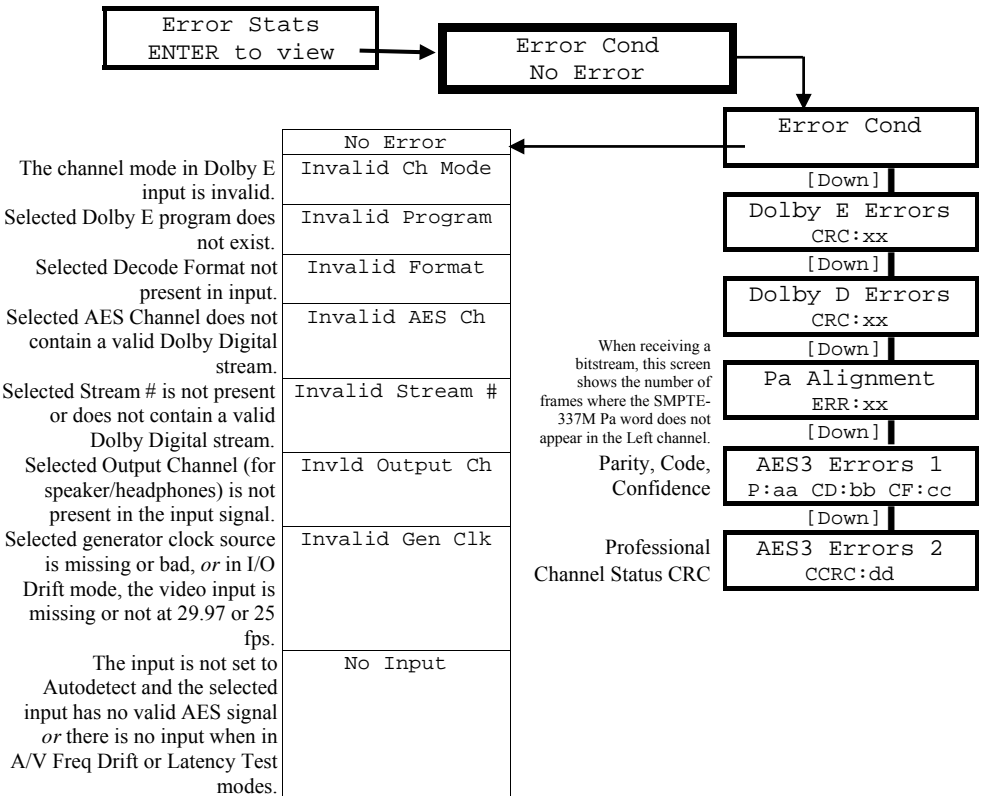

### 3.2.9 DM100 Firmware Version

This last Status menu item displays the version of the firmware currently installed in your DM100.

Firmware Version 2.0.0.0
-----------------------------

Pressing [Down], [Esc], or [Status] returns the display to the top-level Main Status screen.

# Chapter 4

## Operation: Setup Mode

---

### Introduction

Pressing [Setup] switches the DM100 into Setup mode. Use this function to configure your DM100. All setup settings are saved when the unit is turned off. The settings shown in **bold** are the factory defaults. The setup menu choices are:

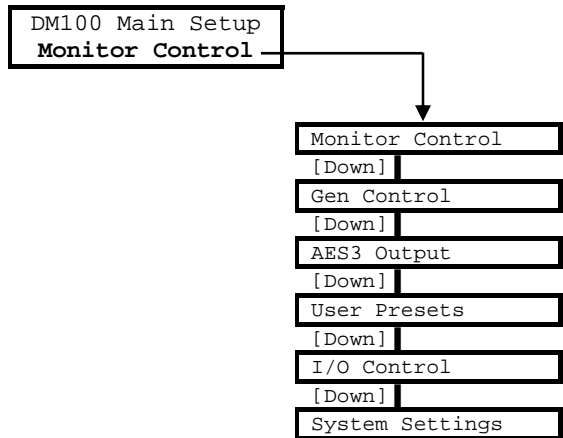

The following pages show the setup selections available for each of the menu choices.

## 4.1 Monitor Control

The Monitor Control menu contains all of the functions that control the audio output of the DM100. After pressing [Enter] to select the Monitor Control menu, press the [Down] or [Up] button to choose the desired setting:

**Decode Format** chooses the type of bitstream the DM100 will decode. This is normally set to Autodetect; however, it is possible to force the DM100 to decode only one stream type, if required.

**Output Ch Map** chooses which audio channels or downmix (Lt,Rt or Lo,Ro) are output from the headphone or speaker.

**Dolby E Prog Sel** selects one of the available programs in a Dolby® E stream for monitoring.

**DE Dialogue Lev** applies the metadata parameter Dialogue Level or “dialnorm” to the audio output of a Dolby E stream.

**DD Stream Select** and **AES3 Ch Select** choose which signal from a multiplexed Dolby Digital bitstream is decoded.

**DD Compression** applies Dolby Digital dynamic range control data to the audio output. RF is the heaviest compression and Custom is the lightest. DD compression can be useful when listening in a noisy environment.

When listening through the speaker, this setting has no effect, and RF Mode is always used.

**Headphone Mode** sets mono or stereo mode for the headphones. Mono = (L+R)/2.

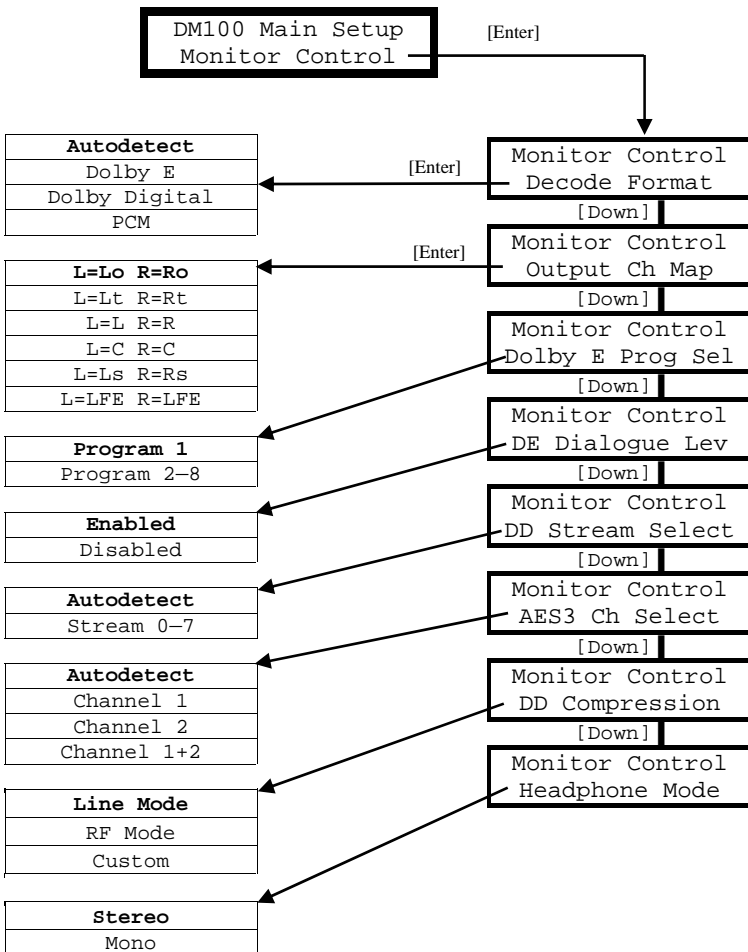

Custom disables dynamic range compression, except when listening to a downmix.

## 4.2 Gen Control

The Gen Control menu contains all of the settings for the bitstream generator. After pressing [Enter] to select the Generator Control menu, press the [Down] or [Up] button to choose the desired setting:

**Output Mode** switches the generator on or off, either passing through the input signal to the output connectors or connecting the generated signal to the output connectors. It also sets the unit to latency measurement or A/V frequency drift measurement modes.

**Gen Stream Sel** selects the generator output stream from a list of Dolby E, Dolby Digital, and PCM streams.

**PCM Waveform** contains the settings for the PCM generator signal, allowing sine, square, sweep, and pink or white noise signals to be created.

**DE Offset** allows the Dolby E bitstream to be placed a number of lines away from the video sync point (a valid video reference input is needed for this function).

**DD Ch Mode** chooses where to place a Dolby Digital stream in the output AES3 stream (Channel 1+2 is the usual setting).

When measuring the latency of external equipment, the **Noise Burst Rate** function sets the frequency of the short noise bursts. See Section 2.7 for more information. The larger the setting, the less frequently the noise bursts are generated, and the larger the latencies that may be measured. However, larger settings increase the time taken to make each measurement.

New bitstreams may be uploaded to the DM100 using the **Upload Bitstream** function. To load and store new streams, connect a Windows® PC to the DM100 using the supplied cable. The baud rate is fixed at 115.2 kbps. Activate the Upload Bitstream function on the DM100 and follow the prompts on the PC software supplied. During the upload, the DM100 display will show progress. When complete, reboot using the [Esc] key.

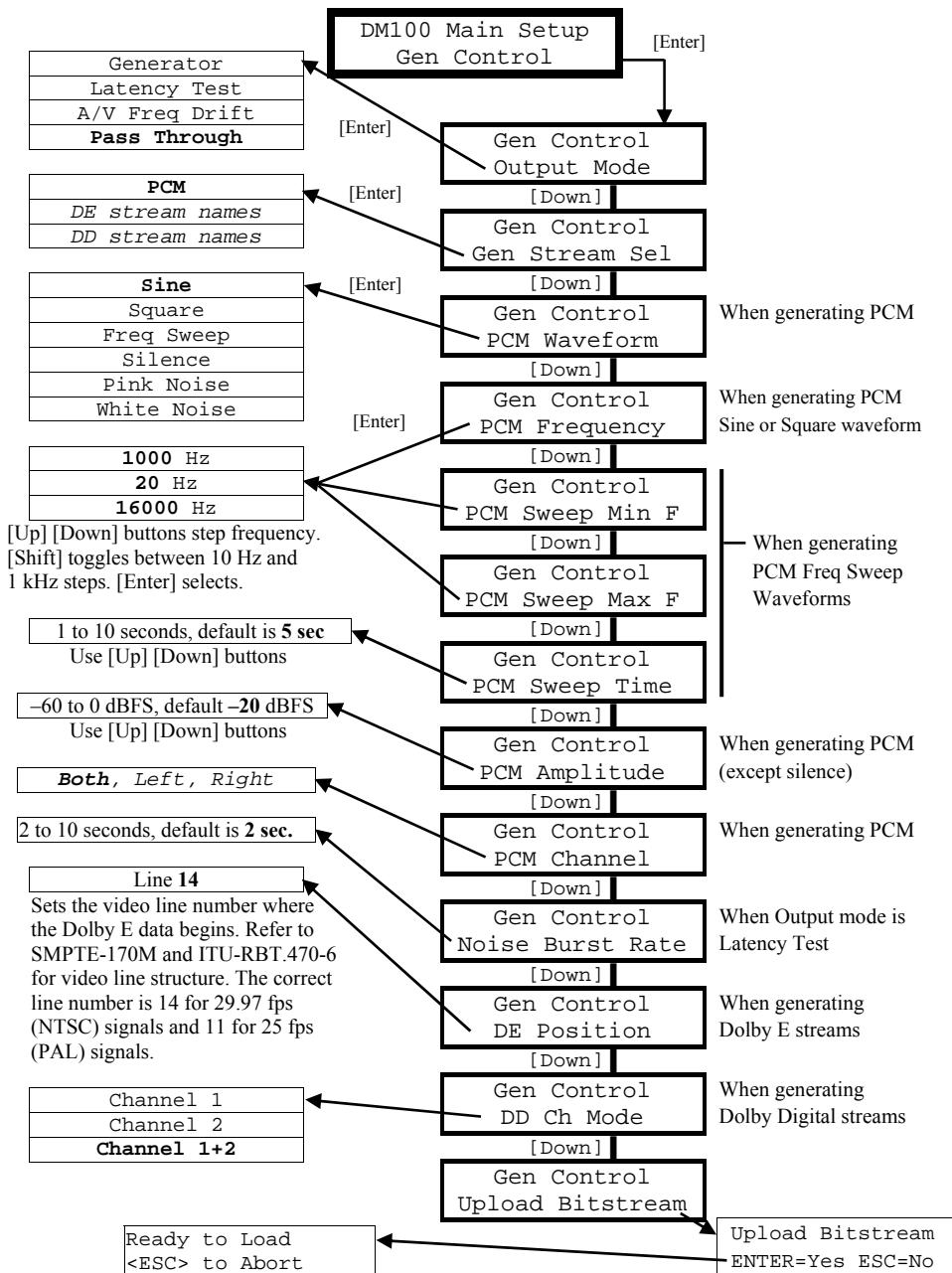

## 4.3 AES3 Output

The AES3 Output menu allows the user to control the value of the AES3 status bits present on the output of the DM100. The output can be set to pass through each parameter from the input (or from the generator), or each parameter can be manually set to a desired value. When a value has been changed, the current decode LED will flash (long on, short off) to indicate this change. To reset all of the parameters, use the Pass Through All function.

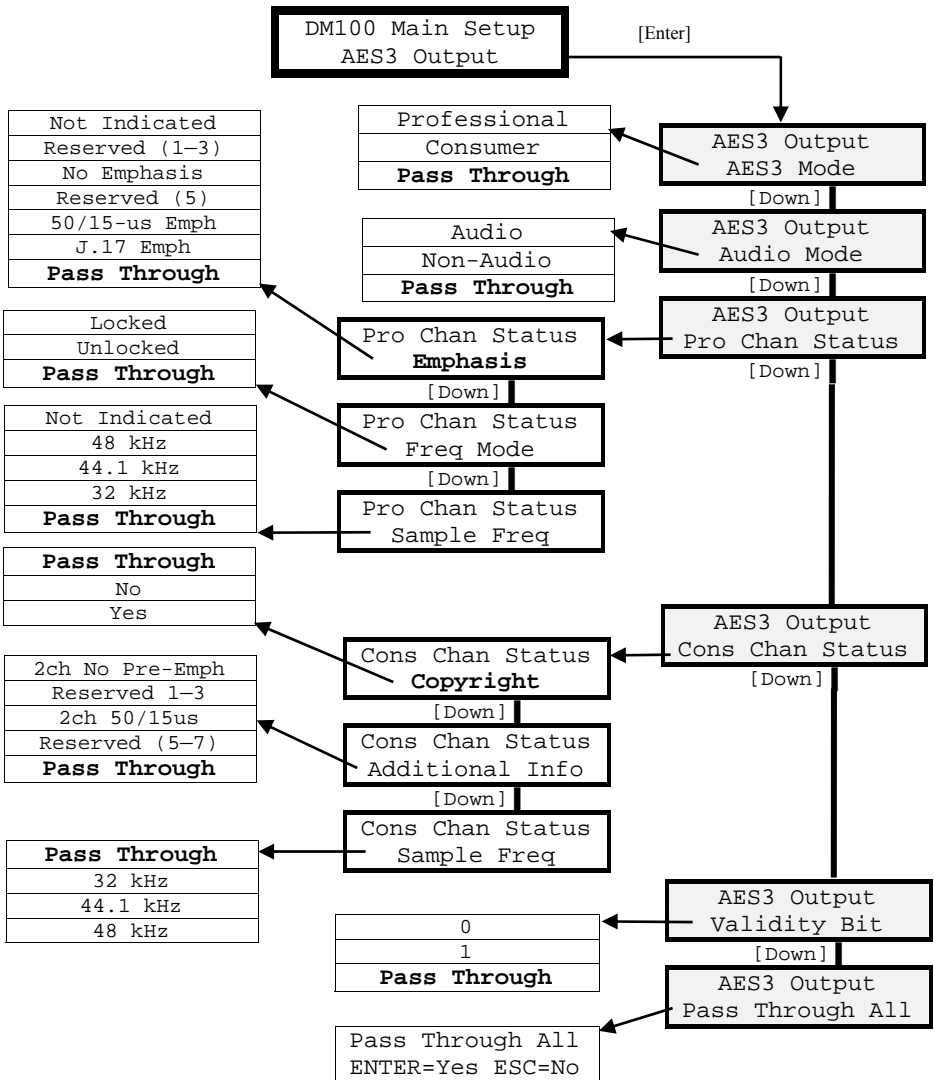

## 4.4 User Presets

Up to four user presets can be saved, named, and recalled. These presets contain a copy of the DM100 setup information.

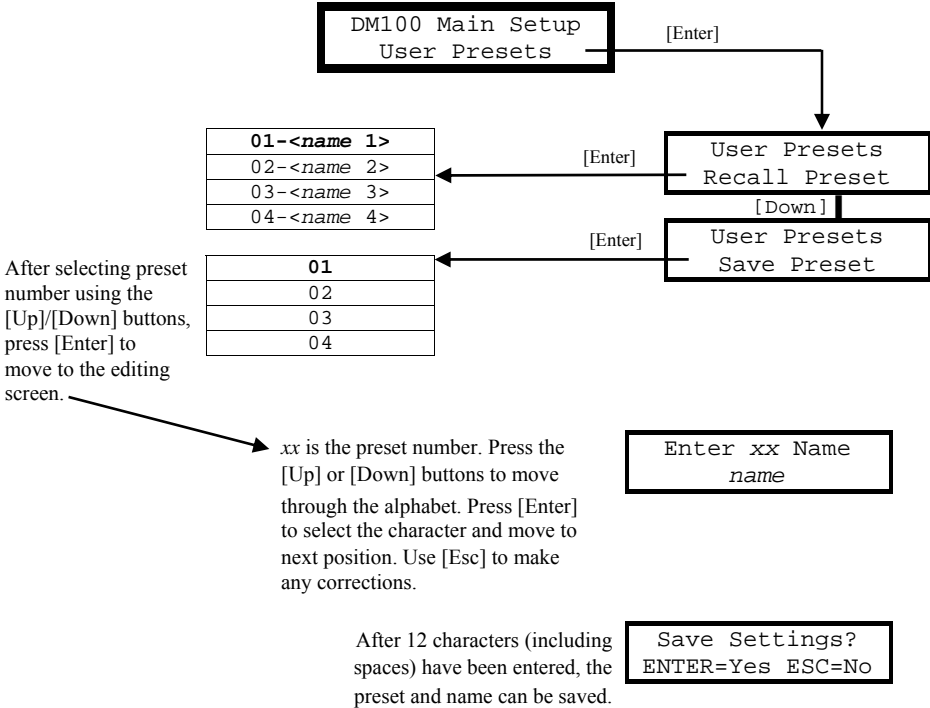

Enter xx Name  
name

Save Settings?  
ENTER=Yes ESC=No

## 4.5 I/O Control

The I/O control menu configures the physical input and output connections of the DM100. **Input Select** allows the user to choose a specific physical input rather than the default of Autodetect. **Gen Clock Source** chooses the reference signal for the generator. **DAC on Non-Audio** sets audio output mute or active when the incoming bitstream is flagged as non-audio data. **Optical Output** switches the Toslink™ optical output on or off. **Optical Output** switches the Toslink™ optical output on or off. If not required, disable it to extend battery life.

**Logging Output** can be used for long-term data recording. See Section 5.1 for more information.

**Passthru Ch Swap** allows the output channels to be swapped or skewed when in Pass Through mode.

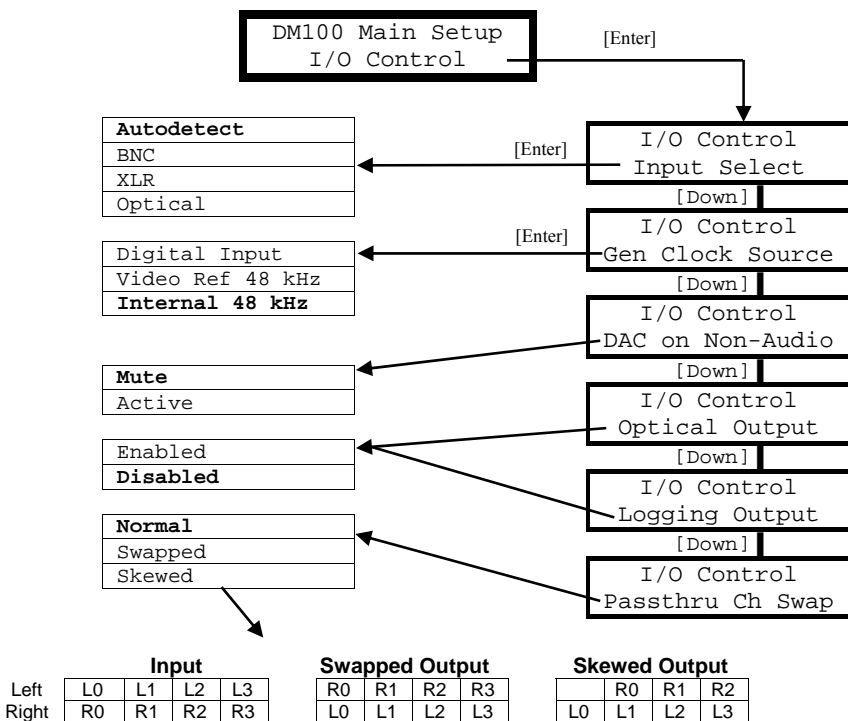

## 4.6 System Settings

The System Settings menu contains options for setting user preferences for the DM100. **RS-232 Baud Rate** controls the speed of the RS-232 port logging data. **Unit Name** allows entry of up to 12 characters to give a DM100 a unique identity. This is displayed during power on. The **Power Management** function controls how long the unit remains switched on after the last button press when operating on battery power. **LCD Backlight** and **Contrast Adjust** control aspects of the LCD. **Firmware Upgrade** is used to load new firmware into the DM100.

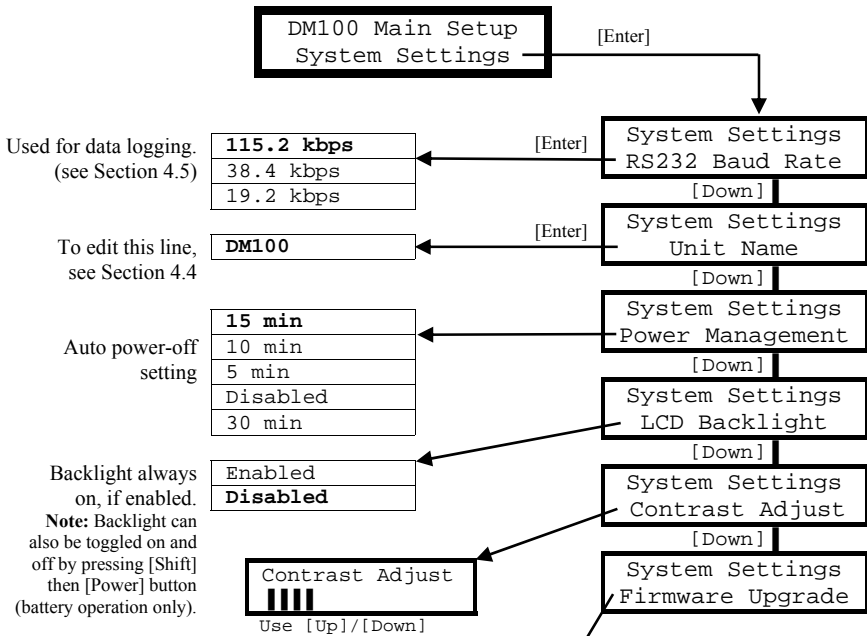

During the upgrade, the display will show progress. When complete, the DM100 will reboot. The data rate is fixed at 115.2 kbps.

**Note:** This function can be accessed directly. Turn off the DM100 by pressing the [Power] button. Press the [Power] button again while holding down the [Setup] button.

---

**Note:** When powered from the external power supply, the Power Management setting is ignored and the unit remains switched on. The LCD backlight and keypad backlights are also turned on, overriding the LCD Backlight setting.

---

# Chapter 5

## Reference Information

---

### 5.1 Data Transfer

Connect the RS-232 port on the front of the DM100 to a computer using the cable provided. The RS-232 serial interface is used for:

- Test bitstream loading.
- Data logging. Status information can be transferred from the DM100 via a terminal program. The status information is transmitted in the form of text messages that can be read on the terminal display.
- Firmware upgrades.

#### **Test Bitstream Loading**

Test bitstream loading is accomplished using the **Gen Control** setup menu. Press the [Setup] button, then use the [Down] button to step to the **Gen Control** menu. See Section 4.2 for more information. The table at the end of this section lists possible error messages. Test bitstreams are loaded at a fixed data rate of 115.2 kbps.

#### **Data Logging**

This function can be used for long-term data recording. Any standard terminal program may be used on the computer. The logged data is in this order: time, parameter, and value. The logged time is the elapsed time since the DM100 was last switched on. A fixed set of parameters is always logged (input format, errors, etc.). One additional parameter may be logged by navigating to the status screen that contains that parameter.

First, set the baud rate you wish to use via the **System Settings** menu: Press the [Setup] button, then use the [Down] button to step to the **System Settings** menu. Press [Enter] and select the desired data rate with the [Up/Down] buttons. Press [Enter] to save. Next, to initiate logging: Press the [Setup] button again, then use the [Down] button to step to the **I/O Control** menu. Press [Enter], then use the [Down] button to step to **Logging Output**. Press [Enter] then use the [Down] button to select Enable. Press [Enter] to start logging via the RS-232 connection to your terminal program. See Sections 4.5 and 4.6.

## Firmware Upgrade

With the DM100 powered off, press the [Power] button, then hold down the [Setup] button. The DM100 will display the Firmware Upgrade screen. The data transfer operates at a fixed data rate of 115.2 kbps. If an error occurs during the upgrade, the Error LED illuminates, an error message is displayed, and the data transfer halts.

Pressing the [Esc] button exits the upgrade mode if data is not being transferred, or turns the unit off if a data transfer error occurs.

## Data Transfer Error Messages:

Error Message Display	Description
HDR CHKSUM ERR	Invalid checksum in file's header.
HDR LENGTH ERR	Invalid length in file's header.
DATA CHKSUM ERR	Invalid checksum in data portion of file.
DATA LENGTH ERR	Invalid data length specified in file's header.
FLASH INIT ERR	Flash memory detection failed: device code not recognized.
FLASH ERASE ERR	Flash sector protected and can not be erased.
FLASH PGM ERR XX AT ADDR YYYYYY	Flash not blank at address YYYYYY (hex). Flash module error code given in XX (hex).
IMAGE SIZE ERR	Error in downloaded image size or address: Too large for either RAM or flash.
VERIFY ERR	Programmed image in flash does not match downloaded image after programming.
PRODUCT ERR	Product code in file's header is not "DM100."
FLASH MEM FULL	No space left in flash memory (when loading test bitstreams).
TOO MANY STREAMS	There is a limit of 200 streams in the unit.

## 5.2 Unit Reset

### Restore Default Settings

With the DM100 powered off, press [Power] while holding down the [Enter] button. The factory default settings are restored without changing your presets or stored test bitstreams.

### Hardware Reset

In the unlikely event that the restore procedure above does not work, the unit can also be reset by inserting a pen point or paper clip into the **RESET** hole on the back of the DM100. The unit will reset and power off.

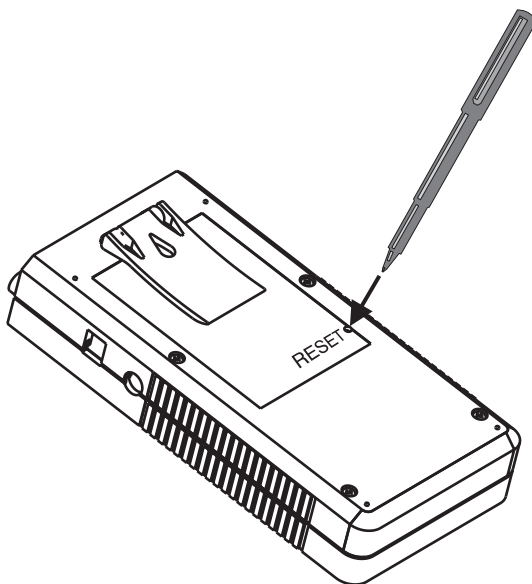

## 5.3 Connector Pinout Information

### 5.3.1 RS-232 Serial Port

Pin	Connection	Description
1	NC	
2	NC	
3	RX	Asynchronous data out
4	Ground	
5	TX	Asynchronous data in
6	NC	
7	NC	
8	NC	

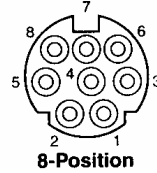

**Note:** This unit is a DCE device designed for connection to a DTE device. The TX is the data input and the RX is the data output

### 5.3.2 XLR Connectors

Pin	Connection
1	Signal Ground
2	Signal +
3	Signal -

### 5.3.3 Headphone Connector

Pin	Connection
Tip	Left Channel
Ring	Right Channel
Sleeve	Common

## 5.4 DM100 Specifications

### Sampling Rates

48 kHz for all modes,  
32 kHz and 44.1 kHz for Dolby Digital  
and PCM

### Video Frame Rates

29.97 and 25 fps

### Frequency Response

Digital Outputs: 20 Hz–20 kHz,  $\pm 0.25$  dB

### Distortion

<0.01% at 1 kHz  
<0.02%, 20 Hz–20 kHz

### Dynamic Range

>100 dB

### Digital Audio Inputs

AES/EBU via XLR female connector,  
110 $\Omega$ .

AES3ID-1995/SMPTE 276M

via BNC connector, 75 $\Omega$

Fiber optic via Toslink™ connector

Input word lengths up to 24 bits

Supported digital bitstreams:

16- and 32-bit Dolby Digital,

Consumer Dolby Digital,

16-, 20-, and 24-bit Dolby E,

Non-audio AES3

### Reference Video Input

Analog composite NTSC or PAL black  
burst video reference, 1 V<sub>p-p</sub>, via RCA  
connector, 75 $\Omega$  internally terminated

### Digital Audio Outputs

AES/EBU via XLR female connector,  
110 $\Omega$ .

AES3ID-1995/SMPTE 276M

via BNC connector, 75 $\Omega$

Fiber optic via Toslink connector

Output word lengths up to 24 bits

### Serial Input/Output Port

8-pin female mini DIN, RS-232

### Headphone Output

+5.8 dBu max (adjustable) into 600 $\Omega$ ,  
1/8-inch standard stereo headphone jack

### Case

ABS plastic handheld enclosure

### Dimensions and Weight

100 × 200 × 41 mm

(4 × 7.9 × 1.6 inches)

Net 0.68 kg (1.5 lb)

### Environmental Conditions

Operating: 0° to 50°C (32° to 122°F),

0–98% relative humidity (non-  
condensing)

Non-operating: –20° to +70°C

(–68° to +158°F)

### Power Requirements

External 6 VDC, 800 mA

or four internal 1.5 V AA batteries

Typical battery life 10 hours, continuous  
use

### Supplied Accessories

User's manual

Warranty card

Carrying case

Batteries

External DC power adapter

BNC (F)-to-RCA (M) adapter for video  
reference input,

RCA (F)-to-BNC (M) adapters for the

two audio inputs,

RS-232 serial data cable

Bitstream CD-ROM

### Regulatory Notices

**North America:** This unit complies with  
the limits for a Class A digital device,  
pursuant to Part 15 of the FCC rules, and  
Industry Canada ICES-003 regulations.

**Europe:** This unit complies with the  
requirements of EMC Directive  
89/336/EEC.

# 5.5 System Block Diagram

