

Dolby[®]
DP563
Dolby Surround and
Pro Logic II Encoder
User's Manual

Issue 3

Part Number 91690

Dolby Laboratories, Inc.

Corporate Headquarters

Dolby Laboratories, Inc.
100 Potrero Avenue
San Francisco, CA 94103-4813
Telephone 415-558-0200
Fax 415-863-1373
www.dolby.com

European Headquarters

Dolby Laboratories, Inc.
Wootton Bassett
Wiltshire, SN4 8QJ, England
Telephone (44) 1793-842100
Fax (44) 1793-842101

DISCLAIMER OF WARRANTIES:

EQUIPMENT MANUFACTURED BY DOLBY LABORATORIES IS WARRANTED AGAINST DEFECTS IN MATERIALS AND WORKMANSHIP FOR A PERIOD OF ONE YEAR FROM THE DATE OF PURCHASE. THERE ARE NO OTHER EXPRESS OR IMPLIED WARRANTIES AND NO WARRANTY OF MERCHANTABILITY OR FITNESS FOR A PARTICULAR PURPOSE, OR OF NONINFRINGEMENT OF THIRD-PARTY RIGHTS (INCLUDING, BUT NOT LIMITED TO, COPYRIGHT AND PATENT RIGHTS).

LIMITATION OF LIABILITY:

IT IS UNDERSTOOD AND AGREED THAT DOLBY LABORATORIES' LIABILITY, WHETHER IN CONTRACT, IN TORT, UNDER ANY WARRANTY, IN NEGLIGENCE, OR OTHERWISE SHALL NOT EXCEED THE COST OF REPAIR OR REPLACEMENT OF THE DEFECTIVE COMPONENTS OR ACCUSED INFRINGING DEVICES, AND UNDER NO CIRCUMSTANCES SHALL DOLBY LABORATORIES BE LIABLE FOR INCIDENTAL, SPECIAL, DIRECT, INDIRECT, OR CONSEQUENTIAL DAMAGES, (INCLUDING, BUT NOT LIMITED TO, DAMAGE TO SOFTWARE OR RECORDED AUDIO OR VISUAL MATERIAL), COST OF DEFENSE, OR LOSS OF USE, REVENUE, OR PROFIT, EVEN IF DOLBY LABORATORIES OR ITS AGENTS HAVE BEEN ADVISED, ORALLY OR IN WRITING, OF THE POSSIBILITY OF SUCH DAMAGES.

Table of Contents

Fuse Information	ix
Chapter 1 Introduction	
1.1 Summary of Terms	1-2
Chapter 2 Setup	
2.1 Unpacking.....	2-1
2.2 Jumper Setting	2-1
2.3 Digital Inputs and Outputs.....	2-2
2.4 Metadata	2-3
2.5 Front Panel.....	2-3
2.4.1 Front-Panel Interface.....	2-4
Navigation Buttons	2-4
2.4.2 Contrast Adjust	2-4
2.4.3 Preset Buttons	2-4
2.4.4 LFE Limiter.....	2-5
2.4.5 O/P Limiter	2-5
2.4.6 Input	2-5
2.4.7 Output.....	2-5
2.6 Status Menu	2-5
2.7 Setup Menu.....	2-5
2.6.1 Selecting Parameters	2-6
2.6.2 Entering Text.....	2-7
2.8 Front-Panel Indicators	2-8
2.7.1 Digital Input Status LEDs.....	2-8
2.7.2 Fault, Error, Test, Ref In, Limiter, and Remote LEDs	2-9
2.7.3 Channel-Activity LEDs.....	2-9
2.7.4 Remote Connector.....	2-10
Chapter 3 Quick Start Guide	
Chapter 4 Calibration	
4.1 Introduction	4-1
4.2 Calibration Procedure.....	4-2

Chapter 5 Front-Panel Menus

5.1	Status Menu	5-1
	Main Status.....	5-1
	Other Status Menus	5-1
5.2	Setup Menu	5-2
5.2.1	Operating Mode.....	5-2
	Coding Mode.....	5-2
	Auto/Manual Calibrate	5-2
5.2.2	Metadata Control.....	5-2
	Metadata Source.....	5-3
	Reversion Mode	5-3
	Override Parameters.....	5-3
5.2.3	Internal Params.....	5-4
	Center Trim	5-4
	Surround Trim	5-4
	LFE Trim.....	5-4
	Surround Source.....	5-4
	LFE Source.....	5-5
	LFE Filter	5-5
	LFE Limiter.....	5-5
5.2.4	Postprocessing.....	5-5
	Output Limiter.....	5-5
	Output Trim.....	5-5
5.2.5	User Presets	5-6
	Recall Preset.....	5-7
	Save Preset	5-7
5.2.6	I/O Control	5-7
	Input Channels.....	5-7
	Clock Source	5-7
	Output Word Length	5-8
	Coding Delay.....	5-8
	Bypass Mode.....	5-8
5.2.7	System Settings	5-8
	Remote Baud Rate.....	5-8
	Unit Address.....	5-8
	Unit Name	5-9
	Test Tone.....	5-9
	Firmware Upgrade.....	5-9

Chapter 6 Connectors and Specifications

6.1	Connectors	6-1
6.1.1	Digital Audio Connections.....	6-1
	Inputs.....	6-1
	Outputs	6-1
6.1.2	Ref In.....	6-1
6.1.3	Metadata Serial Port.....	6-2
6.1.4	Rear-Panel Remote Control Serial Port (Remote)	6-2
6.1.5	Front-Panel Remote Control Serial Port (Remote).....	6-3
6.2	Specifications	6-3
6.2.1	Mechanical/Electrical Specifications.....	6-3
6.2.2	Environmental Specifications	6-3
6.2.3	Audio Specifications	6-4
6.2.4	DP563 Block Diagram.....	6-5

Appendix A Mixing with Dolby Pro Logic II

A1	Introduction	A-1
A2	Setup	A-1
A3	Mixing Issues.....	A-3
A3.1	Upmixing	A-4
A3.2	Announcers and Dialogue.....	A-5
A3.3	Interior Effects.....	A-5
A3.4	Positioning of the Stereo Image	A-6
A3.5	Stacking Encoded Tracks.....	A-6
	Magic Surround.....	A-6
A3.6	Decoder Mistracking and Steering Artifacts.....	A-7
A3.7	Surround Pumping	A-7
A3.8	Proper Surround Level and Content.....	A-8
A3.9	Limiters, Delays, Reverb Units, Other Effects Processors	A-8
A3.10	Mono to Stereo Synthesizers.....	A-8
A3.11	Mono, Stereo, and Dolby Surround Compatibility	A-8
A3.12	Common Pitfalls	A-9

List of Figures

Figure 2–1 Jumper Locations	2-2
Figure 2–2 DP563 Front Panel	2-3
Figure 2–3 Front-Panel Buttons.....	2-4
Figure 2–4 Front-Panel Indicators	2-8
Figure 6–1 DP563 Rear Panel	6-1
Figure 6–2 DP536 Block Diagram	6-5

List of Tables

Table 2–1 Status Menu Navigation Buttons	2-5
Table 2–2 Setup Menu Navigation Buttons.....	2-6
Table 2–3 Commands that Exit the Setup Menu	2-6
Table 2–4 Navigation in Text Entry Menu	2-7
Table 2–5 Digital Input LED States	2-8
Table 2–6 Status LED States	2-9
Table 2–7 Channel Activity LED States.....	2-10
Table 3–1 Presets	3-1
Table 5–1 Preset Configurations.....	5-6
Table 5–2 Input Channel Configurations.....	5-7
Table 6–1 Metadata Serial Port Pin Assignments	6-2
Table 6–2 Rear-Panel Remote Control Serial Port Pin-Outs.....	6-2
Table 6–3 Front-Panel Remote Control Serial Port Pin Assignments.....	6-3
Table 6–4 Mechanical Specifications	6-3
Table 6–5 Environmental Specifications.....	6-3
Table 6–6 Audio Specifications.....	6-4

Regulatory Notices and Fuse Information

FCC

This equipment has been tested and found to comply with the limits for a Class A digital device, pursuant to Part 15 of the FCC Rules. These limits are designed to provide reasonable protection against harmful interference when the equipment is operated in a commercial environment. This equipment generates, uses, and can radiate radio frequency energy and, if not installed and used in accordance with this instruction manual, may cause harmful interference to radio communications. Operation of this equipment in a residential area is likely to cause harmful interference in which case the user will be required to correct the interference at his or her own expense.

Canada

This Class A digital apparatus complies with Canadian ICES-003.

UL

WARNING: *Troubleshooting must be performed by a trained technician. Do not attempt to service this equipment unless you are qualified to do so.*



Check that the correct fuses have been installed. To reduce the risk of fire, replace only with fuses of the same type and rating.

Exposed portions of the power supply assembly are electrically “hot”. In order to reduce the risk of electrical shock, the power cord **MUST** be disconnected when the power supply assembly is removed.

The ground terminal of the power plug is connected directly to the chassis of the unit. For continued protection against electric shock, a correctly wired and grounded (earthed) three-pin power outlet must be used. Do not use a ground-lifting adapter and never cut the ground pin on the three-prong plug.

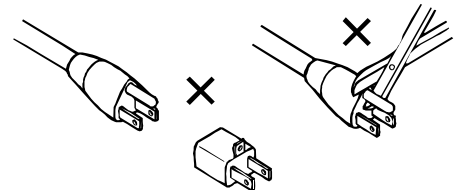

UK

The power cord Dolby part 92021 supplied for use in Europe is not suitable for use in the UK. To use the cord in the UK cut off the CEE7/7 plug and replace with an approved BS 1363 13A plug:

The core that is coloured green and yellow must be connected to the terminal in the plug identified by the letter **E** or by the earth symbol \perp or coloured green or green and yellow.

The core that is coloured blue must be connected to the terminal that is marked with the letter **N** or coloured black.

The core that is coloured brown must be connected to the terminal that is marked with the letter **L** or coloured red.

This apparatus must be earthed.

EU

This equipment complies with the EMC requirements of EN55103-1 and EN55103-2 when operated in an E2 environment in accordance with this manual.

IMPORTANT SAFETY NOTICE

This unit complies with the safety standard EN60065. The unit shall not be exposed to dripping or splashing and no objects filled with liquids, such as coffee cups, shall be placed on the equipment. To ensure safe operation and to guard against potential shock hazard or risk of fire, the following **must** be observed:

- o Ensure that your mains supply is in the correct range for the input power requirement of the unit.
- o Ensure **fuses** fitted are the **correct rating and type** as marked on the unit.
- o The unit **must be earthed** by connecting to a correctly wired and **earthed** power outlet.
- o The **power cord** supplied with this unit must be wired as follows:

(GB)

Live—Brown Neutral—Blue Earth—Green/Yellow

IMPORTANT – NOTE DE SECURITE

Ce matériel est conforme à la norme EN60065. Ne pas exposer cet appareil aux éclaboussures ou aux gouttes de liquide. Ne pas poser d'objets remplis de liquide, tels que des tasses de café, sur l'appareil. Pour vous assurer d'un fonctionnement sans danger et de prévenir tout choc électrique ou tout risque d'incendie, veuillez à observer les recommandations suivantes.

- o Le selecteur de tension doit être placé sur la valeur correspondante à votre alimentation réseau.
- o Les fusibles doivent correspondre à la valeur indiquée sur le matériel.
- o Le matériel doit être correctement relié à la terre.
- o Le cordon secteur livré avec le matériel doit être câblé de la manière suivante:

(F)

Phase—Brun Neutre—Bleu Terre—Vert/Jaune

WICHTIGER SICHERHEITSHINWEIS

Dieses Gerät entspricht der Sicherheitsnorm EN60065. Das Gerät darf nicht mit Flüssigkeiten (Spritzwasser usw.) in Berührung kommen; stellen Sie keine Gefäße, z.B. Kaffeetassen, auf das Gerät. Für das sichere Funktionieren des Gerätes und zur Unfallverhütung (elektrischer Schlag, Feuer) sind die folgenden Regeln unbedingt einzuhalten:

- o Der Spannungswähler muß auf Ihre Netzspannung eingestellt sein.
- o Die Sicherungen müssen in Typ und Stromwert mit den Angaben auf dem Gerät übereinstimmen.
- o Die Erdung des Gerätes muß über eine geerdete Steckdose gewährleistet sein.
- o Das mitgelieferte Netzkabel muß wie folgt verdrahtet werden:

(D)

Phase—braun Nulleiter—blau Erde—grün/gelb

NORME DI SICUREZZA – IMPORTANTE

Questa apparecchiatura è stata costruita in accordo alle norme di sicurezza EN60065. Il prodotto non deve essere sottoposto a schizzi, spruzzi e gocciolamenti, e nessun tipo di oggetto riempito con liquidi, come ad esempio tazze di caffè, deve essere appoggiato sul dispositivo. Per una perfetta sicurezza ed al fine di evitare eventuali rischi di scossa elettrica o d'incendio vanno osservate le seguenti misure di sicurezza:

- o Assicurarsi che il selettore di cambio tensione sia posizionato sul valore corretto.
- o Assicurarsi che la portata ed il tipo di fusibili siano quelli prescritti dalla casa costruttrice.
- o L'apparecchiatura deve avere un collegamento di messa a terra ben eseguito; anche la connessione rete deve avere un collegamento a terra.
- o Il cavo di alimentazione a corredo dell'apparecchiatura deve essere collegato come segue:

(I)

Filo tensione—Marrone Neutro—Blu Massa—Verde/Giallo

AVISO IMPORTANTE DE SEGURIDAD

Esta unidad cumple con la norma de seguridad EN60065. La unidad no debe ser expuesta a goteos o salpicaduras y no deben colocarse sobre el equipo recipientes con líquidos, como tazas de café. Para asegurarse un funcionamiento seguro y prevenir cualquier posible peligro de descarga o riesgo de incendio, se han de observar las siguientes precauciones:

- o Asegúrese que el selector de tensión esté ajustado a la tensión correcta para su alimentación.
- o Asegúrese que los fusibles colocados son del tipo y valor correctos, tal como se marca en la unidad.
- o La unidad debe ser puesta a tierra, conectándola a un conector de red correctamente cableado y puesto a tierra.
- o El cable de red suministrado con esta unidad, debe ser cableado como sigue:

(E)

Vivo—Marrón Neutro—Azul Tierra—Verde/Amarillo

VIKTIGA SÄKERHETSÅTGÄRDER!

Denna enhet uppfyller säkerhetsstandard EN60065. Enheten får ej utsättas för yttre åverkan samt föremål innehållande vätska, såsom kaffemuggar, får ej placeras på utrustningen. För att garantera säkerheten och gardera mot eventuell elchock eller brandrisk, måste följande observeras:

- o Kontrollera att spänningsväljaren är inställd på korrekt nätspänning.
- o Kontrollera att säkringarna är av rätt typ och för rätt strömstyrka så som anvisningarna på enheten föreskriver.
- o Enheten måste vara jordad genom anslutning till ett korrekt kopplat och jordat el-uttag.
- o El-sladden som medföljer denna enhet måste kopplas enligt följande:

(S)

Fas—Brun Neutral—Blå Jord—Grön/Gul

BELANGRIJK VEILIGHEIDS-VOORSCHRIFT:

Deze unit voldoet aan de EN60065 veiligheids-standaards. Dit apparaat mag niet worden blootgesteld aan vocht. Vanwege het risico dat er druppels in het apparaat vallen, dient u er geen vloeistoffen in bekertjes op te plaatsen. Voor een veilig gebruik en om het gevaar van elektrische schokken en het risico van brand te vermijden, dienen de volgende regels in acht te worden genomen:

- o Controleer of de spanningscarroussel op het juiste Voltage staat.
- o Gebruik alleen zekeringen van de aangegeven typen en waarden.
- o Aansluiting van de unit alleen aan een geaarde wandcontactdoos.
- o De netkabel die met de unit wordt geleverd, moet als volgt worden aangesloten:

(NL)

Fase—Bruin Nul—Blauw Aarde—Groen/Geel

Fuse Information



WARNING: To reduce the risk of fire, replace fuses only with the same type and rating.

The unit uses a universal switching power supply that handles the full range of nominal mains voltages between 90 and 264 VAC and any frequency between 50 Hz and 60 Hz.

Check Main Fuse

The Main fuse rating is:

T 1A L (1 Amp, 250 V, 20 mm, time-lag, low breaking capacity) for all operating voltages.

1. Open the fuse compartment door in the AC power input housing with a small flat-blade screwdriver. Carefully pull out the fuse carrier.

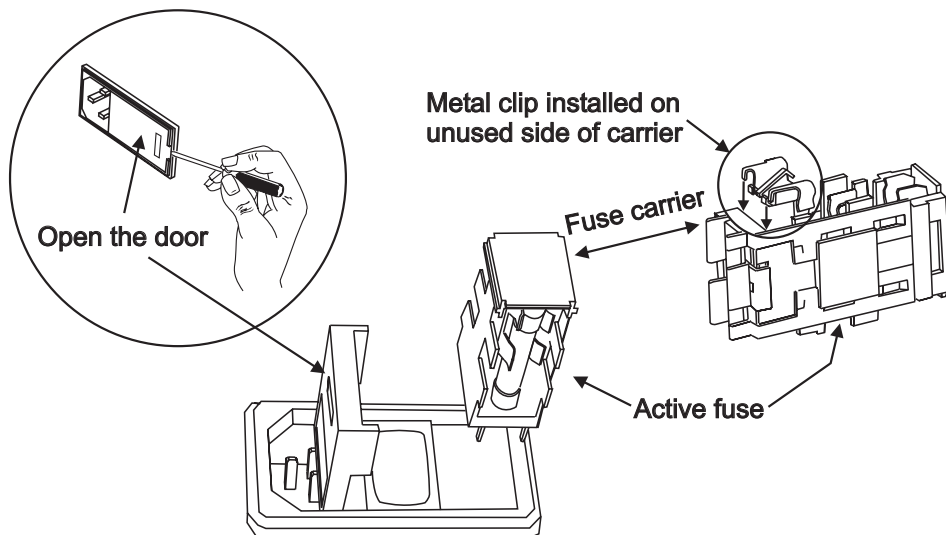

Checking the Main Fuse

2. Check that the fuse has the correct rating. The fuse carrier must be inserted into the compartment with the orientation shown in the figure above. *Do not force the carrier into the compartment or both could be damaged.*
3. Snap the fuse compartment door closed.

Internal Fuse

The switching power supply contains a separate fuse. Most fault conditions should be protected by the main fuse. If you find it necessary to replace the internal fuse, be certain to replace it with a fuse of the same type and rating as printed on the switching power supply board.

Chapter 1

Introduction

The DP563 Dolby® Surround and Pro Logic® II Encoder is designed to encode multichannel program material for Dolby Surround or Dolby Pro Logic II release. The resulting matrix-encoded, two-channel material can be distributed via any analog or digital consumer medium, such as television broadcasts, radio, PC and console games, CDs, and VHS tapes. Facilities creating surround content for two-channel distribution formats will find the DP563 an invaluable tool.

The original Dolby Surround Pro Logic system features four channels: Left, Center, Right, and a mono, band-limited (100 Hz to 7 kHz) Surround channel. Dolby Pro Logic II is an updated matrix surround system providing full-range stereo surrounds (Left and Right Surround) and improved matrix steering, resulting in greater channel separation and an exceptionally stable soundfield.

The DP563's Dolby Surround encoder uses a digital implementation of the Dolby Surround matrix encoder used in the analog SEU4 Dolby Surround Encoder. The DP563 encodes four input channels and produces a two-channel output signal that is compatible with stereo and mono playback, and full four-channel playback over systems equipped with Dolby Surround Pro Logic decoding.

The DP563's Dolby Pro Logic II encoder combines five input signals into the matrix-encoded, two-channel Dolby Pro Logic II format (consisting of a Left total/Right total, or Lt/Rt, signal). Programs encoded in Dolby Pro Logic II provide five-channel playback on systems equipped with Dolby Pro Logic II decoding, and are fully backward compatible for playback on Dolby Surround Pro Logic, stereo, and mono systems.

The DP563 can also premix discrete, 5.1-channel material to the four or five channels required for Dolby Surround or Dolby Pro Logic II matrix encoding. Individual input level trims are provided for the Center, Surround, and Low-Frequency Effects (LFE) channels. Processing on the LFE channel includes a switchable limiter and a lowpass filter.

For broadcasters and facilities using Dolby E technology, the DP563 provides an automatic method for creating either a Dolby Pro Logic II or Dolby Surround Lt/Rt mix for stereo broadcast from the multichannel source. The metadata authored during the production is used to configure the DP563, eliminating the need for operator supervision.

While the DP563 is not designed for the final mixing of matrix-encoded theatrical film soundtracks (Dolby Laboratories manufactures dedicated film sound encoders for that purpose), it can be used to preview the effects of the matrix process on

discrete four-channel elements (“4:2:4 monitoring”) to be included in a film soundtrack’s final mix.

For monitoring purposes, the Dolby DP564 Multichannel Audio Decoder is an ideal companion to the DP563, offering digitally implemented Dolby Pro Logic II and Dolby Surround Pro Logic decoding.

1.1 Summary of Terms

Dolby Surround—The term Dolby Surround refers to Left, Center, Right, and mono Surround channel content that has been matrix encoded to a Left total/Right total, or “Lt/Rt,” signal. The term Dolby Surround was also used to refer to the first generation of surround decoders, although this decoding technology was replaced by Dolby Surround Pro Logic in 1987. Although not a technically correct reference, the encoded Dolby Surround content is often referred to as Dolby (Surround) Pro Logic content.

Dolby Surround Pro Logic—As stated earlier, this term refers to updated Dolby Surround decoding technology featuring an active matrix decoder.

Dolby Pro Logic II—This term refers to both the latest matrix decoding technology and the content that has been encoded to take full advantage of the five channels available in a Dolby Pro Logic II decoder.

Lt/Rt—As stated earlier, this term refers to a signal that has been matrix encoded as Dolby Surround or Dolby Pro Logic II.

Lo/Ro—Left only/Right only, a phrase used to refer to five-channel audio that has been downmixed to two channels without being encoded into Dolby Surround or Dolby Pro Logic II.

Chapter 2 Setup

2.1 Unpacking

Before unpacking the DP563, inspect the outer carton for shipping damage. If the carton shows damage, inspect the unit in those areas.

Several accessories are provided with the unit.

- US style power cord
- European power cord
- BNC 75Ω terminators, rack-mount screws, washers, and fuses
- Hex wrench for cover screws
- User's manual

2.2 Jumper Setting

The DP563 allows you to choose options that are configured by internal jumpers. The factory default settings are shown in **Figure 2–1**. These are suitable for most installations.

To gain access to these jumpers, remove the top cover of the unit as follows:



WARNING: *The main power cable to the unit must be disconnected when the following steps are performed. Ensure that a suitably qualified person is performing this task.*

1. Remove the 12 screws securing the top cover to the chassis. (Use the supplied hex wrench to remove the three screws on the upper front panel.)

Note: The front panel is attached to the chassis by means of three screws at the lower end of the front panel. Do not remove these screws.

2. Gently lift the top cover upward and toward the rear, and set aside.
 3. Reverse the above procedure when reassembling the unit.
-

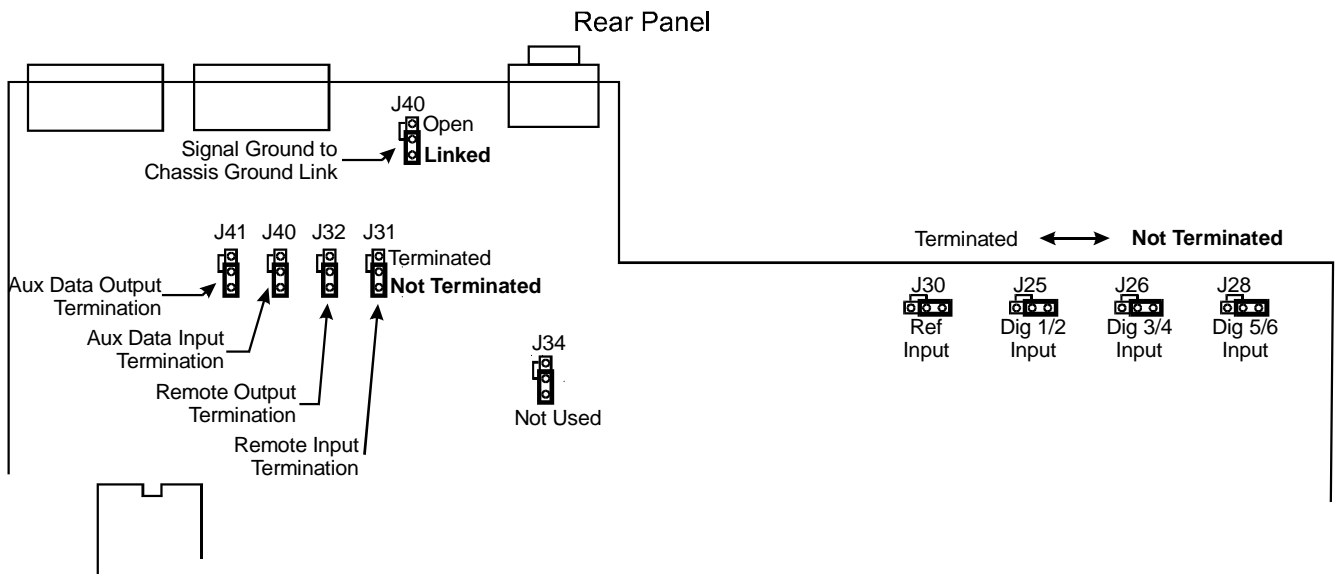

Figure 2-1 Jumper Locations

Note: The Aux Data terminations relate to the port labeled “Metadata” in later units.

2.3 Digital Inputs and Outputs

The digital input and output connections on the DP563 may seem unfamiliar to the first-time user of a digital audio device. The Audio Engineering Society (AES) created a standard electrical interface for digital audio with a balanced XLR connector and 110Ω impedance. This interface is called AES3-1995. This interface was later expanded to include an unbalanced BNC connector, 1 V peak-to-peak signal level, and 75Ω impedance; the new standard is known as both AES3-ID-1995 and SMPTE-276M. The DP563 uses this standard.

Note: These signals must be properly terminated with a 75Ω impedance on the last device in the signal chain. External 75Ω terminations for standard installations are supplied within the packing kit for the DP563.

2.4 Metadata

The Metadata port (labeled “Aux Data” on earlier units) is for use with external metadata signals generated by products such as a Dolby® E decoder or the Dolby DP570 Multichannel Audio Tool.

When the DP563's Metadata Source parameter is enabled, it uses the external metadata to configure the channel trims within the unit. Metadata can also apply additional processing, including dialogue normalization. For further information about metadata, including descriptions of the separate parameters, see the document *Dolby Metadata Guide* available on the Web at www.dolby.com

The unit will follow the following parameters, some of which can be overridden (see Section 5.2.2):

- Channel mode
- LFE channel
- Dialogue normalization
- Downmix parameters (the unit will use the extended bitstream information parameters when these are available)
- Surround 3 dB attenuation

Note: When external metadata is in use, and the preferred downmix selection in the external metadata is ‘Lo/Ro’, then dependant on the setting of the metadata override parameters (see 5.2.2 Metadata Control), the product may output an Lo/Ro output. As this is not a Dolby Surround or Dolby Pro Logic II encoded signal, it should not be labeled as such.

2.5 Front Panel

The DP563 front-panel interface consists of a two-line alphanumeric liquid crystal display (LCD), a set of user input buttons, a set of LED status indicators, and a remote port.

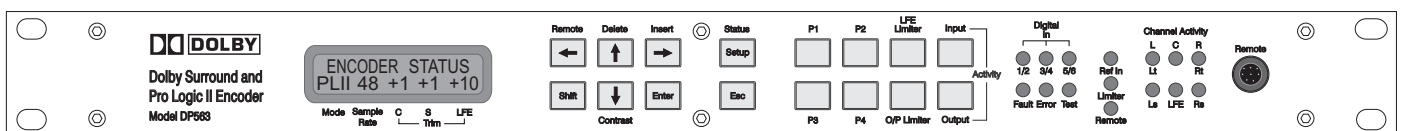

Figure 2–2 DP563 Front Panel

2.5.1 Front-Panel Interface

The menu system has two independent structures: setup and status. The setup menu allows you to configure the DP563 to suit your environmental and program requirements, and the status menu displays information regarding the operating status and the condition of input signals.

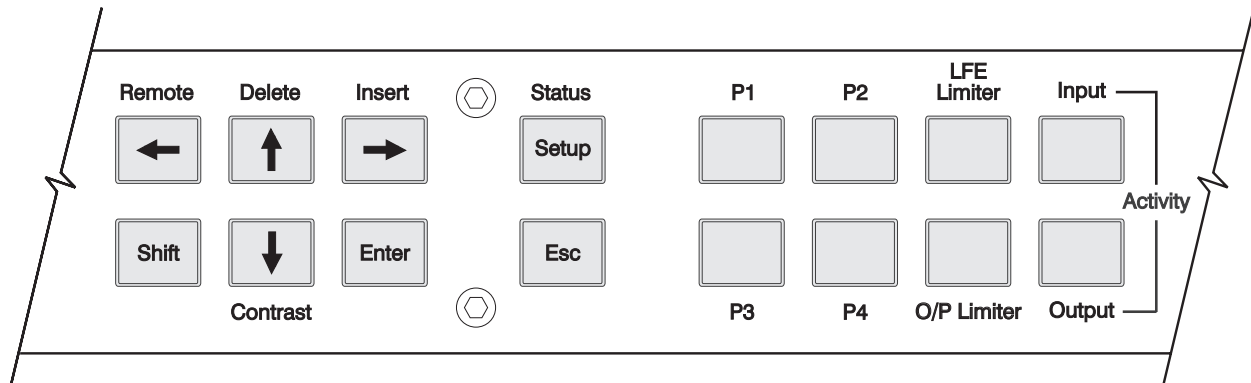

Figure 2–3 Front-Panel Buttons

Navigation Buttons

The eight buttons closest to the display window control navigation through the menus and selection of parameters within menu screens.

To select the function listed above or below a button, first press **Shift**, then the associated button. For example, to select Remote, press **Shift**, **←**. Do not hold down **Shift** while pressing the second button.

Insert and **Delete** have no impact except in text entry menus. For details on text entry, see Section 2.7.2.

2.5.2 Contrast Adjust

Press **Shift**, **↓** to access the contrast control.

Use the arrow buttons to adjust the contrast on the LCD. Press **Enter** or **Esc** to return to the previous menu.

2.5.3 Preset Buttons

To select a preset, press the appropriate **Preset** button. Please refer to the table of factory default presets in Table 3–1. Presets 29–32 are copied to presets 1–4 when shipped from the factory.

2.5.4 LFE Limiter

The **LFE Limiter** key toggles the LFE limiter on and off. The key illuminates when the LFE limiter is enabled, regardless of whether it is enabled through the menu or from this key.

2.5.5 O/P Limiter

The **O/P Limiter** key toggles the output limiter on and off. The key illuminates when the output limiter is enabled, regardless of whether it is enabled through the menu or from this key.

2.5.6 Input

Pressing the **Input** key causes the channel activity LEDs to display the input channel activity.

2.5.7 Output

Pressing the **Output** key causes the channel activity LEDs to display the output channel activity.

2.6 Status Menu

To navigate the status menu, use the front-panel navigation buttons as shown in Table 2-1.

Table 2-1 Status Menu Navigation Buttons

Command	Result
← or ↑	Displays the previous status menu
↓ or →	Displays the next status menu
Esc	Displays main status menu

2.7 Setup Menu

To navigate the setup menu, use the front-panel navigation buttons as shown in Table 2-2.

Table 2–2 Setup Menu Navigation Buttons

Command	Result
← or ↑	Displays the previous menu item available on line 2 of the display.
↓ or →	Displays the next menu item available on line 2 of the display.
Enter	Enters the menu item on line 2 of the display; changes function status and menu display accordingly.
Esc	Displays the next higher menu level. If you have changed the display from the current parameter value without pressing Enter , Esc returns display to current parameter value.

These commands and results remain constant throughout the setup menu, except during text entry. For details on text entry, see Section 2.7.2.

The commands in Table 2–3 exit the setup menu. (If you are in edit mode of a parameter, the **Status** and the **Remote** keys do not respond.)

Table 2–3 Commands that Exit the Setup Menu

Command	Result
Status	Displays current status menu
Remote	Engages the remote control and displays the main status menu

To return to the setup menu, press **Setup**. If you engage the remote, to use the front-panel status menu you must first disengage the remote by pressing **Shift**, **←**, then **Setup**.

2.7.1 Selecting Parameters

When line 2 of the display includes a flashing cursor, the parameter displayed on that line is not active. Pressing **Enter** activates that parameter. Pressing **Esc** while the cursor is flashing returns line 2 of the display to the active parameter for that menu.

Example:

Clock Source Digital Input█	with flashing cursor
--------------------------------	----------------------

Press **Enter** to activate the Clock Source setting. Press **Esc** to return the display to the active status:

Clock Source Digital Input	without cursor
-------------------------------	----------------

If you press **Enter** from the active status display, there is no change. If you press **Esc**, the next higher menu level displays:

I/O Control Clock Source

2.7.2 Entering Text

In certain situations you will be prompted to enter text. In the text entry window,

Enter Name <u>P</u> RESET 6

the first line prompts you to enter text. The second line displays the current text for the parameter or, if no text is yet defined, a default text string. An underline cursor appears under the first character in the string.

Note: Do not use more than 12 characters, including spaces, for a preset name.

Button functions in Text Entry mode are described in Table 2–4.

Table 2–4 Navigation in Text Entry Menu

Command	Result
← or →	Moves the cursor to the left or right
↑	Displays the next character in the character set
↓	Displays the previous character in the character set
Enter	Saves the text on line 2 temporarily, pending confirmation; changes display to confirmation dialog
Esc	Returns text on line 2 to initial display; if text is unmodified, displays the next higher menu level
Insert	Places a blank space at the cursor location; if there are characters to the right of the cursor, moves all characters one space to the right
Delete	Deletes the character at the cursor location
Remote	Engages the remote control and displays the main status menu

2.8 Front-Panel Indicators

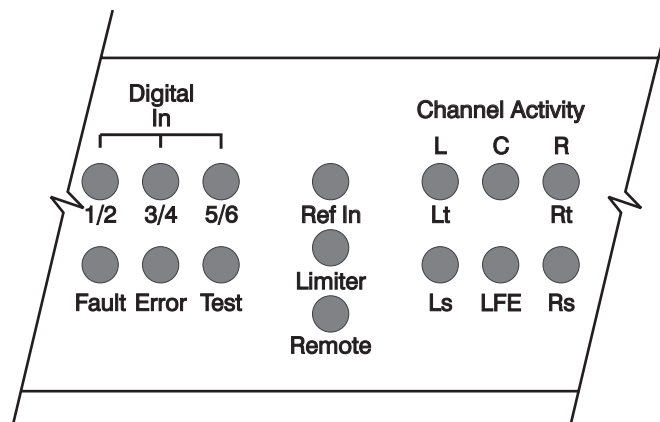

Figure 2-4 Front-Panel Indicators

The front-panel LED indicators provide information on the operational state of the DP563.

2.8.1 Digital Input Status LEDs

The front panel has three status LEDs for audio inputs **Digital In 1/2**, **3/4**, and **5/6**. Each indicates if its respective input is in use and, if so, if it is valid.

Bypass mode does not affect the function of the status LEDs.

Table 2-5 Digital Input LED States

State	Description
Off	Input is unused.
Green	Input is in use and a valid input is detected.
Red	Input is required, but invalid or not present.

2.8.2 Fault, Error, Test, Ref In, Limiter, and Remote LEDs

Table 2–6 Status LED States

LED	State	Description
Fault	Off	PSU and processor status OK.
	Red	PSU or processor/memory fault.
Error	Off	No operational errors are detected by the DP563.
	Red	One or more operational errors are detected and the DP563 output is not valid.
Test	Off	Normal operation.
	Red	Test tone output is enabled. Audio from the system inputs is ignored.
Ref In	Off	The Ref In input is not selected.
	Green	The Ref In input is required and locked without errors.
	Red	The Ref In input is required, but invalid or not present.
Limiter	Off	Both the LFE and output limiters are disabled.
	Green	The LFE and/or output limiters are enabled but not currently active.
	Red	The LFE and/or output limiters are enabled and active.
Remote	Off	Remote interface is disabled.
	Green	Remote interface is enabled and operating without errors.
	Red	Remote interface is enabled, but there is a low-level serial communications error.

2.8.3 Channel-Activity LEDs

There are six channel-activity LEDs. Depending on the status of the input and output activity buttons, these indicate the level of the input or output audio, respectively.

If the LEDs are set to indicate audio at the inputs, and an input channel is muted because its input source is missing or invalid, the respective activity LED turns off.

If the LEDs are set to indicate output audio, only the Lt and Rt activity LEDs illuminate.

If the system is missing its clock signal, then all activity indicators will be turned off even if audio inputs are present.

Table 2–7 Channel Activity LED States

State	Description
Off	Channel is not used or channel is muted due to invalid input.
Yellow	Channel is selected and less than –60 dBFS.
Green	Channel is selected and between –0.1 and –60 dBFS.
Red	Channel is selected and is greater than –0.1 dBFS (clip).

2.8.4 Remote Connector

The front-panel RS-232 port is active only when a connector is physically attached to the port, and either Remote mode or Download mode is enabled.

All front-panel status LEDs, including those on the front-panel preset buttons, are active when the DP563 is in Remote mode. (The buttons themselves, however, are not active).

It is possible to navigate the status screens when in Remote mode.

The Remote mode remains active regardless of whether controlling devices are attached to the remote ports, and whether commands are being received.

Note: Commands from the front-panel remote port override any commands received from the rear-panel port.

Chapter 3

Quick Start Guide

This chapter describes the steps necessary to configure the DP563 for typical operation. Please see indicated sections of this manual for further details.

1. After unpacking the unit, connect the digital audio connections to the DP563, using suitable terminations as required. See Section 6.1.1 for more information.
2. Select the preset that comes closest to meeting your requirements.

Table 3–1 Presets

Preset Number	Preset Name	Coding Mode	Input Configuration	Comments
29 (also Preset 1 following factory reset)	PRO LOGIC II	Dolby® Pro Logic® II	5.0 (For 5.1, enable the LFE channel.)	Recommended configuration for music, gaming, and broadcast.
30 (also Preset 2 following factory reset)	PLII EXT MD	Dolby Pro Logic II	As defined via external metadata.	Where Dolby E metadata is in use.
31 (also Preset 3 following factory reset)	DS 4-CHANNEL	Dolby Surround	L, C, R, S.	Traditional Dolby Surround encoding.
32 (also Preset 4 following factory reset)	DS WITH PREMIX	Dolby Surround	5.1 (For 5.0 disable the LFE channel.)	For creating Dolby Surround content from 5.1 mixes.

3. If the mix was/is created in a room that has been calibrated for film soundtrack creation (85 dBC front channels, 82 dBC rear channels), add an additional –3 dB attenuation to the surround trim. See Section 5.2.3.
4. Before using the DP563 to encode in Dolby Surround, the unit must be properly calibrated. To calibrate, read Chapter 4 for further details.

Chapter 4

Calibration

4.1 Introduction

For the DP563 to operate correctly when encoding Dolby® Surround material, it is important that the unit is properly calibrated to the studio operating level. It is also essential that a calibrated Dolby Surround or Dolby Pro Logic® II monitoring environment be established. Please refer to your Dolby Surround Pro Logic or Dolby Pro Logic II decoder manual (for example, the *Dolby DP564 User's Manual*) for monitoring calibration guidelines.

The DP563 is easily calibrated using an external tone, but consideration must be given to the level this tone has in relation to the levels in the remainder of the recording or transmission system.

As analog operating levels vary from one territory/industry/studio to the next, so do digital operating levels. Below is a selection of typical digital operating levels.

German DIN standard	-15 dBFS	=	-6 dB program level
EBU	-18 dBFS	=	-8 dB program level (BBC PPM 4)
SMPTE (film)	-20 dBFS	=	-6 dB SVA modulation -20 dB digital modulation

The internal operating level (Dolby level) of the DP563 can be configured to any digital level from -26 to -8 dBFS in 0.1 dB steps. The DP563 uses the selected operating level to scale the internal level architecture in a complementary way; this does not alter the audio level through the unit. The default is -20 dBFS. If it is necessary to change from the default value, consideration must be given to levels elsewhere in the signal path.

It is useful to send a reference tone at Dolby level to the recorder or transmission channel so that the rest of the signal chain can be calibrated accurately. This ensures that all Dolby Surround Pro Logic decoders will decode in an expected and accurate manner. The internal test tone generator of the DP563 is scaled along with the operating level and can be used to ensure this.

Note: When it is routed to the Center or Surround channels, the internal test tone level is reduced 3 dB as part of the matrix-encoding process. Therefore, the internal test tone must be routed to either the Left or Right inputs when calibrating.

In general, to avoid overmodulation within the DP563, as with any analog or digital processing equipment, the input levels to the encoder may need to be reduced if they approach the system clip point (in this case, 0 dBFS), or scaled using the Output Trim parameter.

An alternative is to change the operating level of the DP563 to below the -20 dBFS reference by a suitable amount. The output Lt/Rt should then be suitably limited or compressed, and then increased in gain equal to the amount that the operating level was reduced. This method maintains the correct calibration setup for accurate surround decoding, while the internal tone generator still correctly describes the operating level (provided the same make-up gain is applied to both the tone generator and the program).

4.2 Calibration Procedure

There are two methods for calibrating the DP563.

In Auto Calibrate mode, an external 1 kHz tone should be used for calibration set to the studio's standard operating level.

1. Apply the tone to the left input only.
2. Enter Auto Calibrate mode through the Setup/Operating Mode/Auto Calibrate menu. Press **Enter** to commence calibration.
3. The LCD will display *Calibrating...* for a few seconds, and then the measured value will be displayed.
4. The DP563 internal operating level is now calibrated to match the external 1 kHz tone level.

To select Manual Calibrate mode, enter through the Setup/Operating Mode/Manual Calibrate menu.

Use the ↑ and ↓ keys to adjust the internal level, until the LCD display reads the desired level.

Press **Enter** to confirm the selected level.

If at any time you need to reset the internal level back to the default, -20 dBFS, press the ↑ and ↓ keys simultaneously.

Chapter 5

Front-Panel Menus

This chapter provides an overview of the terms and selections available on the front-panel display.

5.1 Status Menu

The main status menu appears when you turn the power on, press the status button combination (**Shift, Setup**), or activate the remote control.

Main Status

Encoder Status
PLII 48 +0 +0 +7

The top line shows the current unit name or the name of the current preset. The second line shows the current encoding status. `Not Encoding` indicates that the unit has been set to use external metadata, Reversion mode is set to `Mute Output`, and the external metadata has been lost or corrupted.

If the unit is encoding, then the second line displays the current value of the coding mode and the sampling rate. If external metadata is in use, this is followed by `Extnd1` and the value of the metadata source/override params/LFE channel parameter. Otherwise, the values of the center trim, surround trim, and internal params/LFE trim parameters display.

Other Status Menus

Information displayed includes:

- Condition of the digital input, reference input, and the selected clock source.
- Current coding delay.
- The metadata input status, its current reversion mode, and the current metadata source. `I` indicates internal parameters, `L` indicates last used; and `M` indicates that the digital output will mute if the metadata is lost or corrupted. An asterisk indicates that parameters are being overridden.
- Firmware version.

5.2 Setup Menu

Options in the top menu level are:

- Operating mode
- Metadata control
- Internal parameters
- Postprocessing
- User presets
- I/O control
- System settings

5.2.1 Operating Mode

Options in the Operating Mode menu are:

- Coding mode
- Auto calibrate
- Manual calibrate

Coding Mode

The DP563 has two operating modes, also known as coding modes. The options are Dolby® Surround and Dolby Pro Logic® II.

Auto/Manual Calibrate

For details of calibration, see Section 4.

5.2.2 Metadata Control

These menu options control whether external metadata is being used and the behavior of the unit in response to various metadata inputs.

Options in the Metadata Control menu are:

- Metadata source
- Reversion mode
- Override parameters

This menu controls the metadata source for the DP563, and dictates how the DP563 is to function when metadata disappears.

Metadata Source

The metadata source parameter selects whether the external metadata is used to configure the unit. When `Disabled` is selected, metadata is not used, and the unit will use the internal parameters. Selecting a specific program number will enable the use of the corresponding program in the external metadata signal.

Reversion Mode

These parameters determine what happens when the external metadata source, if selected, is interrupted or corrupted.

- The last used parameter allows encoding using the last values set by the external source.
- Internal parameters switches to encoding using the internal parameter settings.
- Mute will mute the main digital output of the encoder.

In all cases, the unit returns to using the external metadata source when it is restored.

Override Parameters

This submenu enables you to override various parameters from the external metadata. Metadata parameters that can be overridden include Dialogue Normalization and Surround 3dB Attenuation. When a parameter is being overridden, the value in the external metadata signal will be ignored, and the selection in this menu will be used.

- **Dialogue Level** can be assigned a new value between -31 dBFS and -1 dBFS. Note that the actual average output level will be affected by the output trim (See 5.2.4 Postprocessing).
- **LFE Channel** is excluded by default from the encoding process as it would not be present in a corresponding Dolby Digital downmix. When the LFE channel is present in the incoming stream, it can be included in the encoded Lt/Rt output by enabling this parameter. A trim will also be applied as selected by this parameter's value.
- **Preferred Downmix** is set to Lt/Rt by default to ensure an encoded output. This can also be configured to follow external metadata or to continually output an Lo/Ro signal if so desired.
- **Surround 3dB Attenuation** can be overridden to rectify incorrect settings of this parameter.

5.2.3 Internal Params

The internal parameters configure the preprocessing stages when external metadata is not in use. Options in the Internal Params menu are:

- Center trim
- Surround trim
- LFE trim
- Surround source
- LFE source
- LFE filter
- LFE limiter

Center Trim

The center trim parameter adjusts the level of the Center channel signal prior to the matrix encoding stage. The center trim value defaults to 0 dB; it can also be set to a value between -3 and +3 dB.

Surround Trim

The surround trim parameter adjusts the level of the surround signal(s) prior to the matrix-encoding stage. The surround trim value defaults to 0 dB; it can also be set to a value between 0 and -6 dB. This trim controls both surround inputs.

If the mix is created in a room that has been calibrated for film soundtrack creation (85 dBC front channels, 82 dBC rear channels), add an additional -3 dB attenuation to the surround trim.

LFE Trim

The LFE Trim adjusts the LFE channel level prior to being mixed into the left and right channels. It may be set to a value between -20 dB and +10 dB. The default is +7 dB. This parameter will be used when internal parameters are in use. The Metadata Control/Override Params/LFE Channel will be used when external metadata is in use.

Surround Source

The surround source parameter selects how the Left Surround and Right Surround inputs are used to create the mono surround channel for Dolby Surround encoding. This parameter may be set to $L_s + R_s$ (the sum of Left Surround and Right Surround), $L_s - R_s$ (the difference between Left Surround and Right Surround), L_s (Left Surround only), or R_s (Right Surround only). In Dolby Pro Logic II mode, this parameter is always $L_s = L_s, R_s = R_s$.

LFE Source

The LFE source parameter controls whether the LFE input is enabled or disabled.

LFE Filter

This parameter applies a 120 Hz lowpass filter to the LFE-channel input signal. This filter has the same characteristics as those used in Dolby Digital encoders for the LFE signal.

LFE Limiter

This parameter applies a soft limiter (attack time: 5 ms; release time: 1 s) to the LFE channel signal before it is combined with the Left and Right channels. This limiter prevents high-level signals present in the LFE channel from overloading the encoded output signal, or from modulating the output limiter.

5.2.4 Postprocessing

This menu gives you access to submenus controlling communication with other devices, and for upgrading software.

The submenus are:

- Output Limiter
- Output Trim

Output Limiter

An Output Limiter (attack time 0.5 ms, release time 100 ms) is provided to protect against signal overload. As matrix encoding is an additive process, there is a possibility of multiple high-level input signals creating an overload condition on the output. A hard clipper is used in overload situations when the limiter is disabled.

Output Trim

The Output Trim adjusts the level of the final output signal; it may be set to a value between -10 dB and +4 dB. The default is **0 dB**. The output trim is followed by the output limiter.

5.2.5 User Presets

From the factory, presets 1–4 are identical to 29–32, respectively. Presets 29–32 cannot be modified.

- Preset 29: 5.0 audio to be encoded as Dolby Pro Logic II
- Preset 30: audio encoded using Dolby Pro Logic II with the unit configured by external metadata
- Preset 31: four-channel audio encoded as Dolby Surround
- Preset 32: 5.1 audio premixed to four channels for Dolby Surround encoding

Table 5–1 Preset Configurations

Preset Name	PRO LOGIC II	PLII EXT MD	DS 4-CHANNEL	DS WITH PREMIX
Coding Mode	Dolby Pro LogicII	Dolby Pro LogicII	Dolby Surround	Dolby Surround
Calibration Level	–20 dBFS	–20 dBFS	–20 dBFS	–20 dBFS
Center Trim	0 dB	0 dB	0 dB	0 dB
Surround Trim	0 dB	0 dB	0 dB	0 dB
LFE Trim	+7 dB	+7 dB	+7 dB	+7 dB
Surround Source	Ls=Ls Rs=Rs	Ls=Ls Rs=Rs	Ls	Ls+Rs
LFE Source	Disabled	Disabled	Disabled	Enabled
LFE Filter	Enabled	Enabled	Enabled	Enabled
LFE Limiter	Enabled	Enabled	Enabled	Enabled
Metadata Source	Disabled	Program 1	Disabled	Disabled
Reversion Mode	Last Used	Last Used	Last Used	Last Used
Override/Dialogue level	Ext Metadata	Ext Metadata	Ext Metadata	Ext Metadata
Override/LFE channel	Disabled	Disabled	Disabled	Disabled
Override/Srnd 3dB Attn	Ext Metadata	Ext Metadata	Ext Metadata	Ext Metadata
Override/Pref Dwnmix	Ext Metadata	Ext Metadata	Ext Metadata	Ext Metadata
Output Limiter	Enabled	Enabled	Enabled	Enabled
Output Trim	0 dB	0 dB	0 dB	0 dB
Input Channels*	Mode 4	Mode 4	Mode 2	Mode 4
Clock Source	Digital Input	Digital Input	Digital Input	Digital Input
Output Word Len	20 bits	20 bits	20 bits	20 bits
Coding Delay	Minimum	Minimum	Minimum	Minimum
Bypass Mode	Disabled	Disabled	Disabled	Disabled
Remote Baud Rate	38400 bps	38400 bps	38400 bps	38400 bps
Unit Address	8280	8280	8280	8280

* For definitions of modes see Section 5.2.6, I/O Control, Input Channels

Recall Preset

Any of the 32 presets may be recalled via this menu.

Save Preset

The save preset parameter allows the current configuration to be saved to nonvolatile memory. A name of up to 12 characters can be given to each preset.

5.2.6 I/O Control

Options in the I/O Control menu are:

- Input channels
- Clock source
- Output word length
- Coding delay
- Bypass mode

Input Channels

The Input Channels menu maps digital inputs to audio channels. The DP563 provides six predefined channel mappings. Table 5–2 shows these channel configurations.

Table 5–2 Input Channel Configurations

	Channel Config
Mode 1	L/R Ls/Rs C/LFE
Mode 2	L/C R/Ls Rs/LFE
Mode 3	L/Ls C/Rs R/LFE
Mode 4	L/R C/LFE Ls/Rs
Mode 5	L/R C/Ls Rs/LFE
Mode 6	C/L R/Ls Rs/LFE

Clock Source

Lock the system to either the first audio input, Digital In 1/2, or the reference input, Ref In. When locked to the reference input, sample-rate converters are available on all audio inputs.

- Digital Input: The system clock is taken from Digital In 1/2.
- Ref In-SRC Off: The system clock is taken from Ref In, and sample-rate conversion is disabled.
- Ref In-SRC On: The system clock is taken from Ref In, and sample-rate conversion is enabled.

The unit will only encode if locked within four percent of one of the following sampling rates: 32, 44.1, or 48 kHz.

Output Word Length

The DP563 operates to 24-bit precision. When driving equipment that does not support 24-bit precision, the output may be dithered to a shorter word length. The user may select 16-, 18-, 20-, 22-, or 24-bit word length. The default is 20 bits.

Coding Delay

The coding delay is the delay from any input to the Lt/Rt output. It may be set in either units of video frames and fields, or in milliseconds. The maximum delay is two video frames (PAL or NTSC), or 100 ms. The minimum delay is less than 2 ms.

Bypass Mode

Bypass mode directs the Left and Right inputs to the Lt and Rt outputs. In bypass mode, audio does not pass through any premixing, encoding, limiting, or word-length reduction. The delay is less than 2 ms and is not affected by the coding delay setting.

5.2.7 System Settings

This menu gives you access to submenus controlling communication with other devices, and for upgrading software.

The submenus are:

- Remote Baud Rate
- Unit Address
- Unit Name
- Test Tone
- Firmware Upgrade

Remote Baud Rate

The remote baud rate parameter sets the data rate for remote port communications.

Unit Address

The unit address is four characters long. The first character is limited to the numbers 8–F, and the other characters are restricted to 0–F. The last character must be even.

Unit Name

Assign any text name you wish to your DP563; this is displayed on the top line of the main status menu.

Test Tone

When activated, an internally generated test signal acts as the input to the encoding process, rather than the currently selected input signal. In order to receive a valid output, the selected clock source must be valid.

Firmware Upgrade

Enter the firmware upgrade menu when you have an upgrade to install. Download status information is displayed while in progress and when completed. See the documentation that accompanies the upgrade kit.

Chapter 6

Connectors and Specifications

This chapter describes front- and rear-panel connections, metadata and remote-control serial port pin assignments, and product specifications.

6.1 Connectors

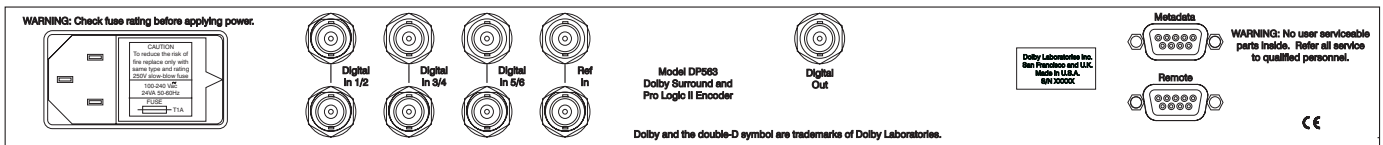

Figure 6–1 DP563 Rear Panel

6.1.1 Digital Audio Connections

Inputs

Digital Inputs (1/2, 3/4, 5/6) for L, R, C, LFE, Ls, Rs channels: BNC female with loop-through, unbalanced, signal levels per AES-3ID-1995, external 75Ω termination required

Outputs

Lt, Rt signals BNC female connector, unbalanced, 75Ω; signal levels per AES-3ID-1995 specifications

6.1.2 Ref In

Reference clock input BNC female with loop-through, unbalanced, signal levels per AES-3ID-1995, external 75Ω termination required. System will lock either to the first digital audio input (Dig In 1/2) or the reference input. The system will not operate without an external clock.

6.1.3 Metadata Serial Port

9-pin female D-connector, electrical specifications per SMPTE 207M. On earlier units, this port is labeled Aux Data.

Table 6–1 Metadata Serial Port Pin Assignments

Pin	Connection
1	Shield
2	TX A asynchronous data out –
3	RX B asynchronous data in +
4	Ground
5	No connection
6	Ground
7	TX B asynchronous data out +
8	RX A asynchronous data in –
9	Shield

6.1.4 Rear-Panel Remote Control Serial Port (Remote)

9-pin female D-connector per SMPTE 207M (RS-485)

Table 6–2 Rear-Panel Remote Control Serial Port Pinouts

Pin	Connection
1	Shield
2	TX A asynchronous data out –
3	RX B asynchronous data in +
4	Ground
5	No connection
6	Ground
7	TX B asynchronous data out +
8	RX A asynchronous data in –
9	Shield

6.1.5 Front-Panel Remote Control Serial Port (Remote)

8-pin female mini-DIN connector, electrical specifications per EIA RS-232

Table 6–3 Front-Panel Remote Control Serial Port Pin Assignments

Pin	Connection
1	No connection
2	No connection
3	TX asynchronous data out
4	Ground
5	RX asynchronous data in
6	No connection
7	No connection
8	Sense select front panel

6.2 Specifications

6.2.1 Mechanical/Electrical Specifications

Table 6–4 Mechanical Specifications

Dimensions	44 × 483 × 305 mm (1.75 × 19 × 12 inches)
Net Weight	4 kg (8.5 lb) approximate
Shipping Weight:	6 kg (13 lb) approximate
Power Requirements	90–264 VAC, 50–60 Hz
Power Consumption	25 W maximum

6.2.2 Environmental Specifications

Table 6–5 Environmental Specifications

Temperature: Operating	0° to 50° C (32° to 122° F), natural convection cooling
Non-Operating (Storage)	–20° to +70° C (–4° to +158° F)
Humidity	20% to 90% relative humidity, non-condensing
EMC Standards: Radiated Immunity	Per EN 55103-1, FCC Part 15 Class A, ICES-003 Per EN 55103-2

6.2.3 Audio Specifications

Table 6–6 Audio Specifications

Audio Coding Algorithms	Dolby® Surround Dolby Pro Logic® II
Audio Sampling Rates	32, 44.056, 44.1, 47.952, and 48 kHz
Frequency Response: L, C, R Channels	Lower limit <20 Hz, upper limit varies with sampling rate ± 0.1 dB
LS, Rs Channels	For Dolby Surround: 100 Hz to 7 kHz, ± 2 dB For Dolby Pro Logic II: Lower limit 100 Hz, upper limit varies with sampling rate ± 2 dB
LFE Channel (low-frequency effects)	<20 to 120 Hz, ± 1 dB (LFE filter enabled)
Total Harmonic Distortion Measured with an Audio Precision System One®	<0.001%, 20 Hz to upper response limit
Jitter	Conforms to AES3-1992 Amendment 1-1997
Dynamic Range	>110 dB
Time Delay input-to-output	User adjustable, minimum to 100 ms in increments of 1 ms or 1 video field. Minimum delay <2 ms (depends on unit configuration).
Input Word Length	24 bits (20 bits when internal sample-rate converter is enabled)
Output Word Length	Adjustable from 16 to 24 bits

Specifications subject to change without notice.

6.2.4 DP563 Block Diagram

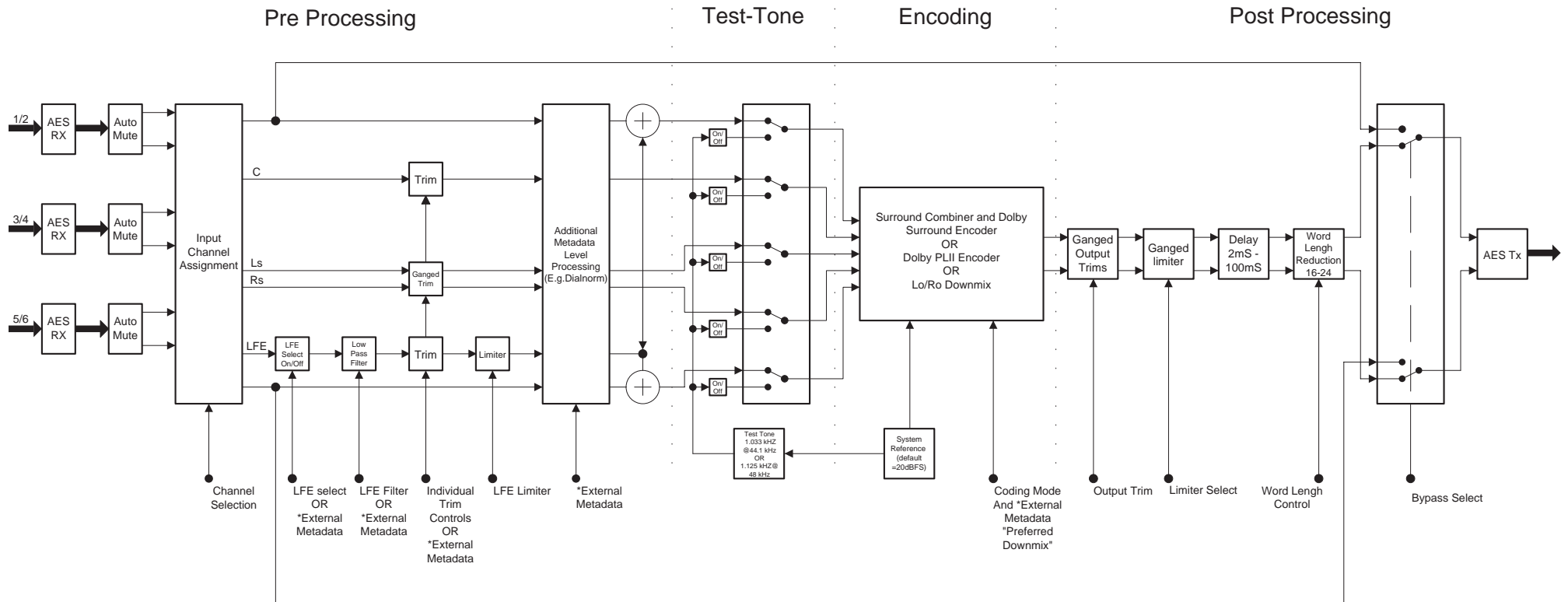

* When External Metadata is in use, these parameters can be overridden.

Figure 6-2 DP563 System Block Diagram

Appendix A

Mixing with Dolby Pro Logic II

A1 Introduction

Dolby® Pro Logic® II is specifically designed to provide a quality multichannel audio experience to listeners of two-channel audio delivery mediums. Dolby Pro Logic II is still a matrix technology and does not sound exactly like the discrete 5.1-channel audio from Dolby Digital soundtracks, but it does effectively emulate that experience.

Dolby Pro Logic II technology is designed to work with existing stereo signals that were not surround encoded. There are several listening modes and user controls that allow listeners to tailor the sound to their liking. Audio soundtracks that are encoded with Dolby Pro Logic II are backward-compatible with Dolby Surround, stereo, and mono listening modes.

For a complete technical description of how the decoder works, a separate paper available from Dolby Laboratories, *Dolby Surround Pro Logic II Decoder: Principles of Operation* by Roger Dressler, explains the decoder and its various modes.

A2 Setup

Those who are familiar with mixing in Dolby Surround will have no problem adapting to Dolby Pro Logic II, as the same considerations for mixing are required.

Monitoring requires proper speaker setup and use of a decoder. The Dolby DP564 Multichannel Audio Decoder handles all of the necessary monitoring functions, bass management, and downmixing. Figure A-1 shows a typical setup.

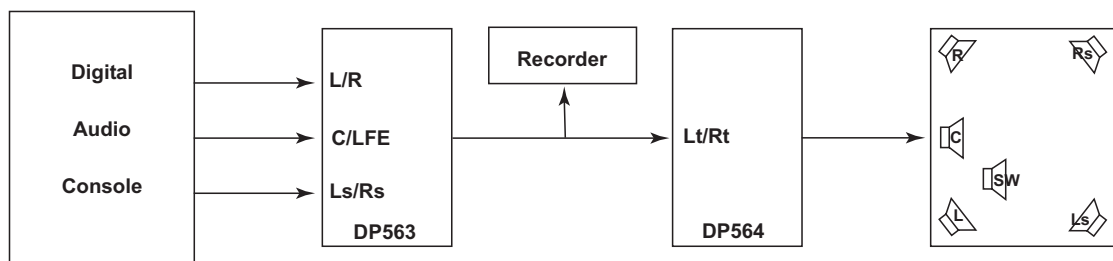

Figure A-1 Audio Flow for Surround Mixing

Speaker placement for Dolby Pro Logic II mixing is the same as it is for Dolby Surround, as shown in Figure A-2.

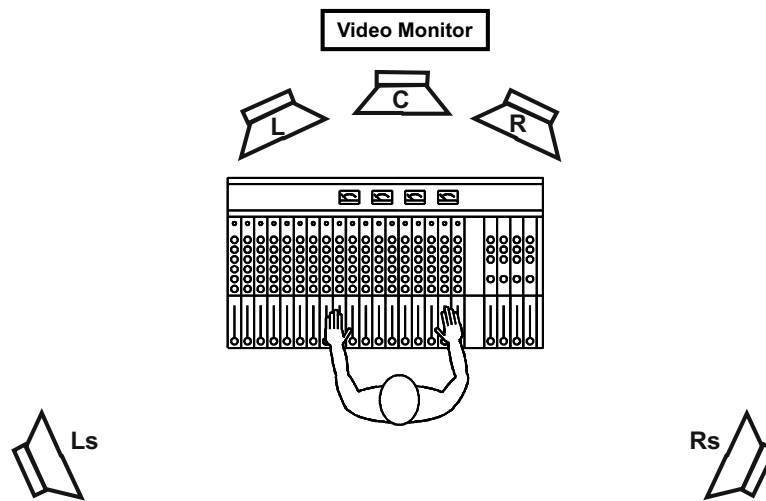

Figure A-2 Speaker Placement: Top View

The surround channels may be used to create a diffuse image, not a direct signal as is typical in 5.1-channel discrete music mixes. In most cases, a compromise is necessary between the ITU-R recommended practice *Recommendation ITU-R BS.775-1* for 5.1-channel speaker placement, and the traditional Dolby Surround speaker recommendations. Contrary to the ITU-R recommended practice, it is not best to place the rear speakers at ear level, pointing directly at the listener. Rather, it is better to position them approximately two feet above the listener's head, pointing at each other, as shown in Figure A-3. These same considerations are used for Dolby Surround and discrete 5.1-channel mixing in a control room.

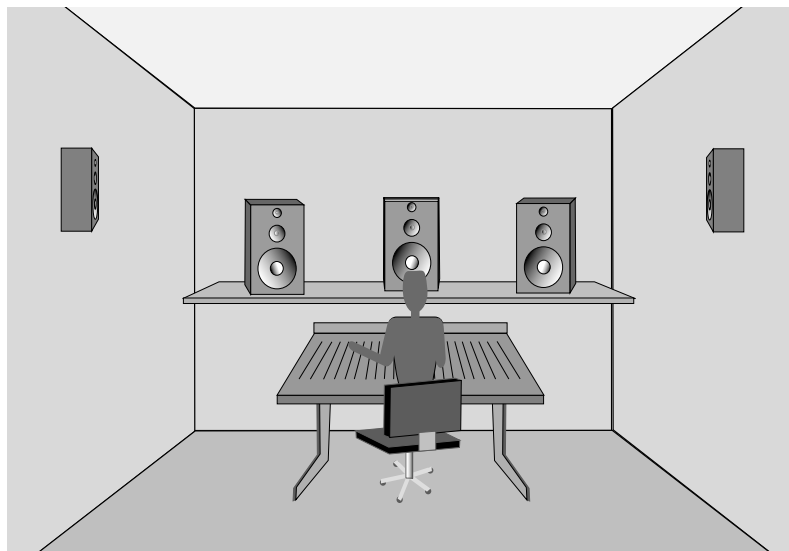

Figure A-3 Vertical Placement of Speakers

Perform system calibration after setting up all of the bass management and delay settings in the DP564. Detailed system calibration instructions are in the DP564

user's manual. This setup should be verified daily. Incorrect monitoring calibration will result in great sounding mixes in your environment, but not outside of it. A quick check with the noise sequencer built into the DP564 and an inexpensive SPL meter generally suffices.

A3 Mixing Issues

When mixing a project, be sure to monitor it in all of the listening modes. Those familiar with Dolby Surround mixing are already aware that any matrix surround mix must be listened to via a decoder to hear the effects of the matrix encoder on the mix. This is where the biggest differences between discrete 5.1-channel audio and matrix encoding systems are evident.

When mixing with Dolby Pro Logic II, Center-channel information appears from the Center channel as expected. However, a matrix decoder doesn't know if the Center-channel information it has is really from the Center-channel input of the encoder—or if it is the result of a signal being present in both the Left and Right channels at equal phase and level. In a discrete system, a signal applied to both the Left and Right channels at the same level is output from the appropriate decoder in the Left and Right channels as it was encoded. Listeners hear the phantom image centered in relation to their position between the Left and Right speakers, as shown in Figure A-4.

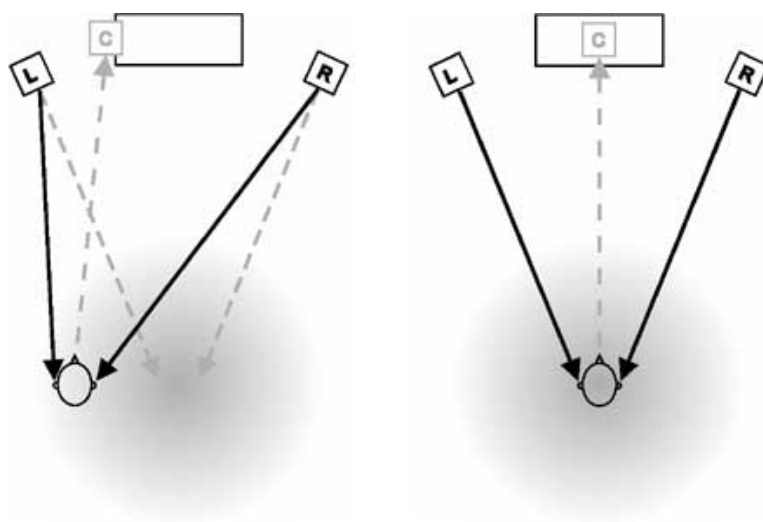

Figure A-4 Phantom Center Images with Listener Off-Center (Left) and in Sweet Spot (Right)

If this signal is processed through a Dolby Pro Logic or Pro Logic II decoder, the decoder redirects this common information to the Center channel output, and a hard phantom image is present from all listening positions. In some cases, the effect is desirable. In others, elements of the mix may appear in the Center channel when their original position was somewhere to the left or right of center, creating what is commonly referred to as “Center-channel buildup.” Because the Dolby Pro Logic II

system was designed to decode material that was not surround encoded, a Center Width control is given to the consumer. This control diverts some of the Center-channel signal back into the Left and Right channels, resulting in a wider center image for the listener. This control affects everything in the Center channel, so dialogue will also be spread out. To obtain the most accurate scenario for Center-channel buildup, we recommend setting the Center Width to zero.

Surround signals can also be manipulated via a Panorama control in some decoding modes. This control works similarly to the Center-channel control described above, but deals with the information present in the Surround channels. Again, use the minimum setting for the Panorama control when mixing.

A3.1 Upmixing

Upmixing is the process of forcing a two-channel source into a 5.1-channel configuration. There are several instances where this might be desirable and a few where it really isn't the right thing to do. Upmixing with a Dolby Pro Logic II decoder—or any other way—should be carefully considered and closely monitored. Both Dolby Surround and Dolby Pro Logic II were designed as single-decode systems. They employ sophisticated techniques that exploit human hearing patterns, giving listeners a perception that doesn't necessarily match the electrical outputs of a unit.

A common reason for upmixing is to deliver a “5.1” mix to the end user, which usually activates a light on the consumer's decoder, letting the consumer know that a 5.1-channel signal is available on their unit. Most consumers are thrilled with this indication of the complete use of the equipment they bought.

The downside to upmixing is that some listeners will have to listen to the signal as a downmix. In this scenario, the original two-channel signal is upmixed to 5.1, delivered to the consumer as such, and then downmixed to a two-channel signal that doesn't match the original (although it is once again a two-channel signal). This is further complicated by the potential for subsequent decoding by a Dolby Surround Pro Logic or Pro Logic II decoder. Depending on the decoding mode used for the upmix and the encoding and downmix parameters used in the Dolby Digital decoder, the signals in the Surround channel may not be correctly timed.

Chances are that delay for the Haas effect in the Surround channel will have been applied twice, once in the upmix and once in the consumer's decoder. The Haas effect for the Surround channel is rendered ineffective, and the perceived separation for the Surround channels is reduced. If the signal is delivered in stereo, a double attack or signal smear may be heard due to the different arrival times of signals common to both front and Surround channels.

There also remains the desire to have the delay present such that the Haas effect is working for those listeners who are using the supplied 5.1-channel mix. Here the 15 ms delay should be used. The real solution to this issue is to send the two-channel signal to consumers and let their decoders handle the decoding.

Upmixing stereo elements for a project that also has discrete 5.1 elements is another challenge. There are many instances where this has been accomplished successfully using Dolby Pro Logic II. While it isn't the same as having a discrete 5.1-mixed element, if your only option is a stereo element, you can use Dolby Pro Logic II.

Any time you are working in this scenario, use Dolby Pro Logic II in Music mode with zero delay in all of the channels. (Use of other listening modes will result in incorrect downmixing in a consumer system, due to Surround phase relationships and delay issues.) Use the Center Width and the Panorama controls to achieve the desired results for each element. Experience has shown that it will probably be necessary to adjust the decoder parameters and channel balances for each element.

We do not recommend using the decoder on complete mixes that include dialogue. If at all possible, keep the dialogue separate, and mix it in during the final mix. In all cases, you should listen through a complete monitoring system that allows for downmixing and decoding of the upmixed signal. The Dolby DP563 with Dolby Pro Logic II and the DP564 are commonly used for this purpose.

A3.2 Announcers and Dialogue

Traditionally, dialogue is placed only in the Center speaker to tie the on-screen sounds to the picture. When a Center speaker is used, all center-panned dialogue appears to come from the screen regardless of the listener's position. If the dialogue comes from the Left or Right speakers, the stereo image differs depending on the listener's position. This is highly undesirable. Generally, only music, effects, or incidental voices should be in any channel other than the Center channel.

A3.3 Interior Effects

Interior sound effects come from all channels and appear to surround the listener. Wind noise, crowds, and other general ambient sounds are included within the mix to provide a sense of realism. Effects and ambient sounds normally appear in the Left, Right, Left Surround, and Right Surround channels. It is common to use stereo ambience that is panned Left and Left Surround for the Left channel of the source, and Right and Right Surround for the Right channel of the source. The resulting sound surrounds the listener, yet still has a front stereo image. The amount of Surround channel signal added determines how far back the listener is in relation to the front sounds. More surround level produces an image that sounds farther back in the room.

A3.4 Positioning of the Stereo Image

The Center speaker in a Dolby Surround system produces stereo imaging that is slightly different than that of a two-speaker stereo system. Most music engineers find this distracting at first, but adjust quickly. Those who mix motion picture sound feel comfortable, as do those music engineers who own a home theater system. The most noticeable difference in the stereo image is that the perceived image tends to be narrower when a Center speaker is used. Because most music mixes contain significant amounts of Center-channel information, we are used to hearing a phantom image produced by the Left and Right speakers. Since all of this information is now directed to a single point source, the Center speaker, we perceive it as being in the center. To correct this in the mix, make the image slightly wider than normal for a two-channel stereo mix.

Do not eliminate the Center speaker in the control room, and use the Phantom Monitoring mode. While omitting the Center speaker may produce a more familiar sound in the control room, it does not satisfy listeners who have a complete home theater system. To achieve the correct listening result, mix with a Center speaker.

A3.5 Stacking Encoded Tracks

In the film industry, it is common to premix elements for the final mix. This can be done for the opening sequence of a broadcast series, or for a sound effect panning through the room for any given program.

The individual elements may be mixed as two-channel elements encoded in Dolby Surround (Lt/Rt), and all of those elements may be mixed together in the final mix. When premixing, assign each element to the Left and Right inputs of the encoder.

Magic Surround

In certain cases, stereo microphone placement techniques and stereo electronic instruments cause a phenomenon known as magic surround. The decoder will decode some of the signal placed in the Surround channel. This results in out-of-phase or inverted information in the stereo pair, which X/Y stereo microphone techniques typically produce. While this may sound pleasing by itself and no encoding seems necessary, it's an unpredictable process that should not be relied upon. Adding another element to the mix, such as a voiceover, could easily change the phase characteristics of the mix and alter the decoding process. It is best to put a little information from this signal source through the encoder's Surround input, ensuring the decoding of the real Surround signals, rather than random out-of-phase information.

In some cases, too much Surround information is present, as with electronic keyboards, which achieve a stereo signal from a mono source via electronic processing. If your favorite sound produces too much information in the Surround channel, simply pan the Left channel a little toward center and the Right an equal amount toward center. This cancels some of the out-of-phase information and corrects

the decoder's steering. The amount of panning required varies with the sound, but it usually does not take much to produce a good result.

A3.6 Decoder Mistracking and Steering Artifacts

When mixing, the decoder can only steer in one direction at a time, so you must plan the soundfield carefully. Movie mixers have been doing this successfully for more than 25 years, so do not be overwhelmed: it can be done quite easily.

Problems result when two very different and unrelated sounds are sent to two different channels at once. For example, crickets in the Surround channels and chickens in the front cause the sounds to bleed into the other channels and produce a dynamic image shift. This effect is distracting and undesirable.

It is also common for a music track to contain a prominent lead instrument in the Left or Right channel while an announcer comes from the Center channel. The instrument appears to move from its intended speaker toward the center when the announcer speaks, and then return to the correct speaker when the announcer pauses. The solution is to either pan the music element toward center or temporarily reduce its level.

Often, when producing motion picture sound effects, the sound designer removes all ambient sounds briefly so that another sound may be heard more prominently. For example, the audio background might contain light traffic noise and night sounds. When a door slams, the traffic and night sounds are either at a very low level or disappear entirely. After the door slams, the background sounds are already back in the mix. Because they were covered by the door slam, the audience doesn't miss them.

A3.7 Surround Pumping

Bad transmission paths frequently cause pumping of the Surround channel that is rarely heard in the mixing environment. Often a limiter is active in one channel of the transmission path but not the other, or a stereo limiter is not set up the same for both channels. You will hear during the mix if a stereo limiter is being used excessively or if only part of the element is limited. The solution is to either remove the limiters or set them up identically and verify that they are linked.

It is impossible to discuss all possibilities, but it is important to always look for inconsistencies between the two stereo channels. The viewer usually recognizes the problem as Surround channel ambience pumping in response to the dialogue. This is particularly noticeable during live sporting broadcasts when there is crowd noise in the Surround channel.

A3.8 Proper Surround Level and Content

When is there enough surround content in a mix? This decision is usually dictated by the taste of the project's producer and engineer. As a guideline, the image should direct attention to the front of the soundfield, and it should be noticeable when the Surround channels are removed from the mix. Attention should not be drawn directly to the Surround channels when they are returned to the mix; the effects should complement, not distract from, on-screen action.

A3.9 Limiters, Delays, Reverb Units, Other Effects Processors

As with any mixing situation, signal processing devices are common in Dolby Surround mixes. Limiters and compressors cause few side effects if they are used prior to encoding. Digital delays, soundfield generators, reverbs, and so forth, may also be used, but their processes may not work as expected in the soundfield when Dolby Surround or Dolby Pro Logic II decoding is used. By monitoring through a decoder, you can instantly hear how the soundfield will actually sound. If you find that your favorite reverb program has excessive surround content before anything is sent to the Surround channel, pan the output a little toward the center instead of hard left and right. The phase shifting of the effects unit competing with the phase encoding found in Dolby Surround and Dolby Pro Logic II causes this effect. Experiment with the panning and level to obtain the desired soundfield.

A3.10 Mono to Stereo Synthesizers

Mono to stereo synthesizers can create all sorts of havoc in a Dolby Surround mix. First, the Dolby Surround program is a stereo signal, so there is no need for a synthesizer in the transmission path. Second, if you have ever listened to a mono show run through an aggressively adjusted stereo synthesizer, and then through a surround decoder, you have heard the dialogue coming from all the speakers simultaneously. All localization of the voices to the screen is lost. For this reason, with complete mixes, a synthesizer is not a desired tool in the transmission path. When used properly, stereo synthesizers can be an advantage for individual mono sources within a Dolby Surround mix and before encoding. They should not, however, be used excessively when dialogue or vocals are part of the mono element.

A3.11 Mono, Stereo, and Dolby Surround Compatibility

Mixing techniques used in Dolby Pro Logic II productions are similar to those used in normal stereo productions. Just as you should check the mono compatibility of a stereo mix, you should also check the mono, stereo, and Dolby Surround compatibility of a Dolby Pro Logic II mix.

Dolby Pro Logic II mixes are consistently compatible with Dolby Surround decoding. The main difference is that the Dolby Surround decoding band-limits the surround channel to 7 kHz, and the surround information is mono.

In most cases, stereo compatibility is not an issue. The mix's surround element will appear to be outside of the speakers, as would an out-of-phase signal. Notice that the entire mix should not sound out-of-phase, and there should still be a hard center image.

Mono compatibility is a little trickier, because any content that is in the Surround channel disappears in mono. This is an asset in some cases and a detriment in others.

In situations such as live sporting events, losing some crowd information in the mono mix helps those at home listening in mono on a three-inch television speaker to hear the announcers more clearly. In other applications, the mix may have a critical element in it that is predominantly in the Surround channel. For this reason, surround elements should also be present in a front channel, interior panned, so they will be heard in mono, as is commonly practiced in the film industry.

A3.12 Common Pitfalls

Although you may like a surround effect that spins your head, and it may be just what your production needs, repeating the move dozens of times usually tires the listener. The key to a good surround mix is subtlety. Don't draw attention to your techniques. The listener should never be distracted from the screen by surround effects. Loud, obnoxious, or out-of-place effects detract from the production. Keep it fun, but tasteful.

Mixes that are surround-heavy distract the viewer from the on-screen action, so do not put too much information in the Surround channel. If you find yourself thinking about what you just heard in the Surround channel instead of paying attention to the action on the screen, you have a problem. Too much surround information may also make dialogue unintelligible.