



Exciting, Versatile, Impactful



Dolby® 3D is unique among 3D solutions. Not only does it provide a superior audience experience and impactful box-office returns, Dolby 3D also is easy to install and operate, surprisingly cost-effective, and better for the environment than competing systems. Economical, eco-conscious, exciting: that's Dolby 3D.



THE RIGHT CHOICE

Dolby 3D is an extension of Dolby Digital Cinema, a powerful, flexible, and reliable technology. Dolby 3D delivers an extraordinary 3D experience that provides vivid color and a sharp, clear image from every seat in the house. Dolby 3D uses the same white screen as 2D features, saving the expense of installing a dedicated silver screen and allowing for more scheduling flexibility. Our eco-friendly reusable glasses are designed to last hundreds of screenings and are a smart alternative to throwaways. Dolby's large-screen solution also enables 3D presentations in the largest auditoriums.

The technology behind Dolby 3D requires only a few additional components in theatres already equipped for digital projection:



A **rotating filter wheel** assembly installed in your existing projector inserts between the lamp and picture element for 3D and retracts for 2D.



A **Dolby Filter Controller (DFC100)** automatically synchronizes the filter wheel with 3D digital content as it's projected.



Lightweight reusable glasses bring the picture to life in amazing color and clarity. The reusable glasses are designed to last hundreds of uses.

How the Dolby 3D System Works

Dolby 3D projects alternating full-color images for the left eye and right eye that are shifted with respect to their primary color frequencies. The audience wears passive glasses with high-fidelity filtering lenses that are precisely tuned to these differences, thereby preventing each eye from seeing the images intended for the other eye. This superior technology eliminates the need for the impractical silver screens or the active-shutter glasses of other systems.

Flexibility

Easily switch between 2D and 3D, and move movies to additional auditoriums without changing a thing.

Efficiency

No silver screen is required. You can use your existing screen, eliminating the expense and drawbacks (such as the hot spot and color inaccuracies) of the special silver screen required by other 3D formats.

Quality

You get vivid color and a sharp, clear image from every seat in the house.



The **Dolby 3D large-screen solution** enables 3D to play back on the largest of screens with the same Dolby 3D sharpness, clarity, and amazing color.

Live 3D

Dolby 3D technology is currently integrated into International Datacasting Corporation's 3D live products. This solution delivers pristine Live Dolby 3D content to your audience.

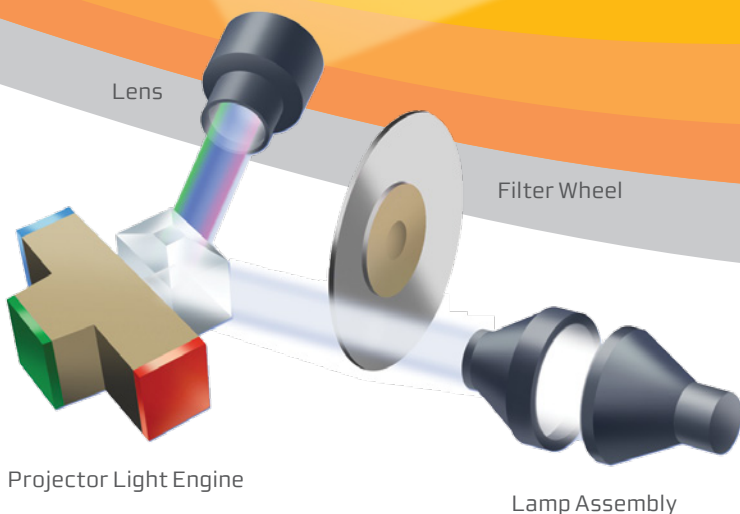

Learn How Easy Dolby 3D Can Be



For more information on how Dolby 3D can transform your theatre, contact your Dolby cinema equipment provider or visit www.dolby.com/3DCinema.

DISCLAIMER OF WARRANTIES

Equipment manufactured by Dolby Laboratories is warranted against defects in materials and workmanship for a period of one year from the date of purchase. There are no other express or implied warranties and no warranty of merchantability or fitness for a particular purpose, or of noninfringement of third-party rights (including, but not limited to, copyright and patent rights).

LIMITATION OF LIABILITY

It is understood and agreed that Dolby Laboratories' liability, whether in contract, in tort, under any warranty, in negligence, or otherwise, shall not exceed the cost of repair or replacement of the defective components or accused infringing devices, and under no circumstances shall Dolby Laboratories be liable for incidental, special, direct, indirect, or consequential damages (including, but not limited to, damage to software or recorded audio or visual material), cost of defense, or loss of use, revenue, or profit, even if Dolby Laboratories or its agents have been advised, orally or in writing, of the possibility of such damages.

**Dolby Laboratories, Inc.**

100 Potrero Avenue, San Francisco, CA 94103-4813 USA T 415-558-0200 F 415-863-1373

dolby.com

Dolby and the double-D symbol are registered trademarks of Dolby Laboratories.
© 2009 Dolby Laboratories, Inc. All rights reserved. S09/19359/21409